

1:20

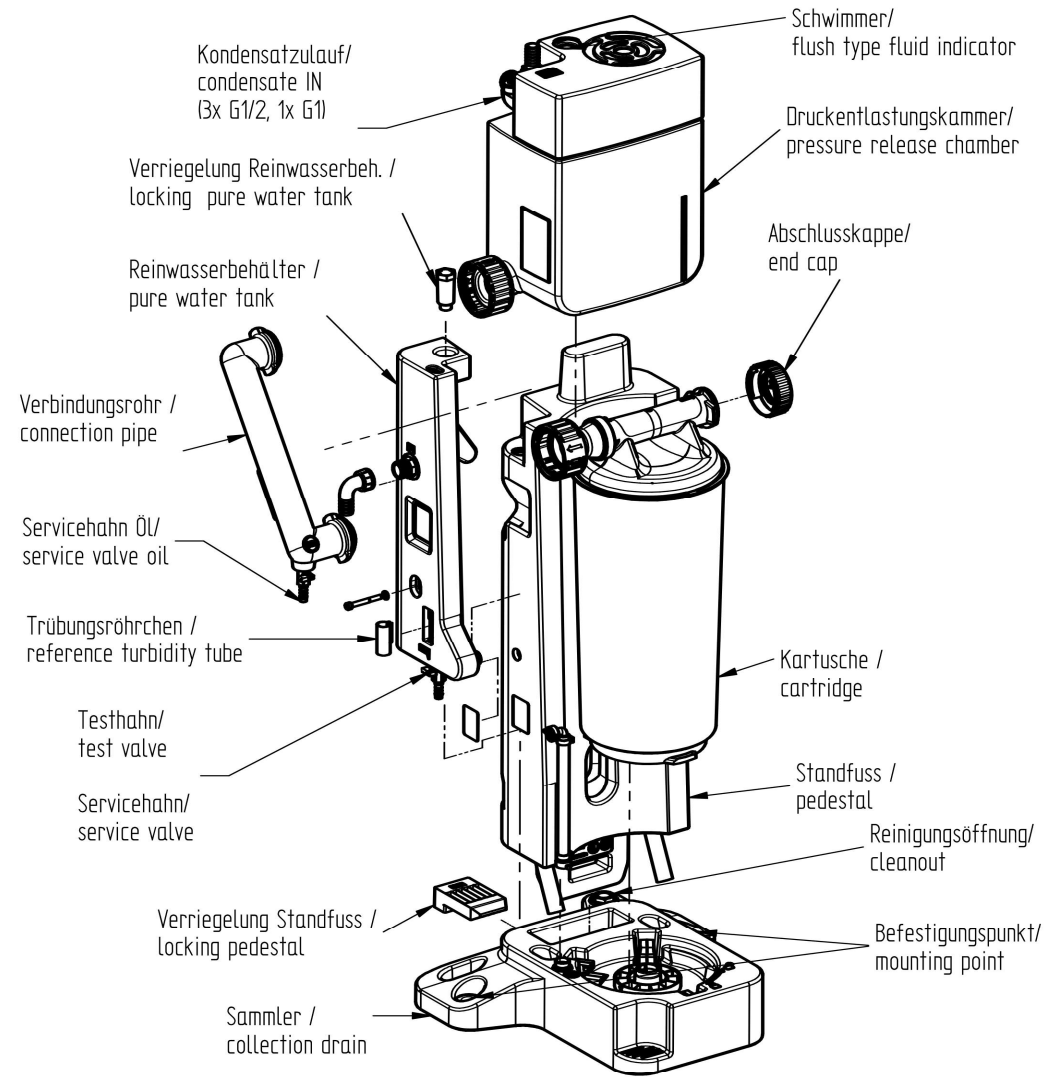
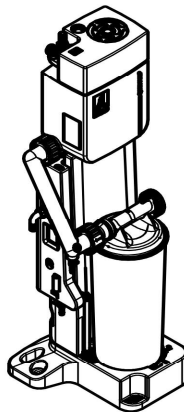

Technische Änderungen vorbehalten ! Technical modifications are subject to change without notice, errors not excluded				Maßstab / scale	Gewicht / weight	Format
Allgemeintoleranzen für Schweißkonstruktionen General tolerance for welded construction DIN 8570 / 18	Allgemeintoleranzen General tolerance ISO 2768-m-k	Werkstückkanten Part edges DIN 6784		1:10	22 kg	A3
				Werkstoff / material		
				Datum	Name	Benennung / Titel
				Gez. 19.09.23	S.Tal	Öl-Wasser-Trenner CSQ-P10 Oil water separator CSQ-P10
				Gepr. 19.09.23	T.Tappe	
				Zeichnungs-Nr. / Drawing no.		ZMP-S101791
				EST GmbH Filtrations-Separations-Technik		
Rev.	Änderung / changes	Date	Name			