

Product Data Sheet

Dew Point Transmitter SP-ESH420

Version: 1.8.0

Author: Tassilo Tappe

Date: 13.07.2018

Field of application

The SP-ESH420 dew point transmitter is designed for measuring the amount of humidity (water vapour content, pressure dew point) of compressed air within the range of -100°C to +20°C pressure dew point at pressure levels up to 450 bar, providing the actual pressure dew point figure as a 4-20 mA signal. The SP-ESH420 dew point transmitter is mainly used for dew point measurement in adsorption dryers. The transmitter, of course, can be used for other applications according to its specifications at any time.



Features

The SP-ESH420 dew point transmitter is designed for ease of use, incorporating all the features needed to make installation and operation as simple as possible. The transmitter provides fast response times and an excellent sensor protection at the same time, is fully configured and calibrated and can be instantly incorporated into a compressed air management and control system. Its measurement range of -100°C to +20°C pressure dew point covers all purity classes of ISO 8573-1. The 2-wire loop powered connection makes electrical installation easy.

Basic data

Model	Nominal volume flow	Max. operating pressure	Min./Max. operating temperature
SP-ESH420	---	450 bar	-40°C - +60°C

Maintenance rules

SP-ESH420	Cleaning and re-calibration after 1 year, earlier if required
-----------	---

Product Data Sheet

Dew Point Transmitter SP-ESH420

Specifications subject to change without notice

Date 13.07.2018

Latest version see www.fstweb.de

Product-specific data

Performance

Specification	
Measurement range	-100°C to +20°C (dew point)
Accuracy	± 2°C (dew point)
Response time	5 mins to T95 (dry to wet)
Repeatability	0.5°C (dew point)

Operating conditions

Specification	
Humidity range	0% - 100%
Required flow rate	1-5 litres/min
Temperature coefficient	Temperature compensated across entire operating temperature range

Electrical

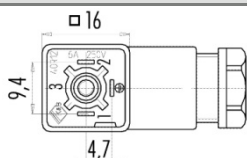
Specification	
Supply voltage	12-28 V DC
Supply voltage influence	± 0.005% RH/V
Current	max. 20 mA
Load resistance	max. 250Ω (12V) ; 500Ω (24V)
Protection Class	IP66 (NEMA 4)
Output signal	4-20 mA for -100°C to +20°C dew point (2-wire)
Output signal at fault conditions	< 4 mA: under-range dew point > 20 mA: over range dew point ≥ 23 mA: sensor fault
Electrical connection	<p>solenoid plug type C - 3+PE industrial standard</p> 

Product Data Sheet

Dew Point Transmitter SP-ESH420

Specifications subject to change without notice

Date 13.07.2018

Latest version see www.fstweb.de

Materials

Component	
Housing	Stainless steel
Sensor protection	HDPE Guard (<10 micron)

Connections, dimensions and weight

Model	Connection	Height	Ø	Weight
SP-ESH420	5/8" UNF	132 mm	27 mm	0.15 kg

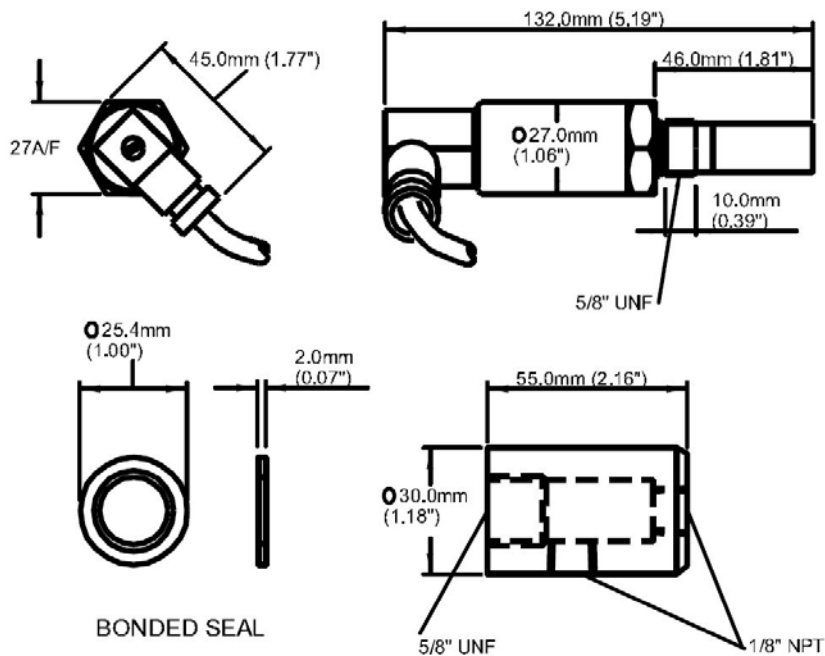

Classification according to Pressure Equipment Directive 2014/68/EU for group 2 fluids

Model	Volume	Category
SP-ESH420	< 0.01 litres	---

Other Directives

Model	
SP-ESH420	---

Product Data Sheet

Dew Point Transmitter SP-ESH420



Specifications subject to change without notice

Date 13.07.2018

Latest version see www.fstweb.de