

Product Data Sheet

Breathing Air Dryer DPS 10-100 BI und BM

Version: 1.4.0

Author: Tassilo Tappe

Date: 16.01.2024

Field of application

Adsorption dryers of the DPS 1-8 BI and BM series are designed for drying and purification of compressed air for breathing air applications. ..BI stands for „Breathing air Industrial“, thus for Industrial use acc. EN12021, and ..BM stands for „Breathing air Medical“, thus medical breathing air acc. Pharmacopée Européenne, as it is demanded for hospitals.

With both systems apart from the drying process to a pressure dew point of -40°C also the components CO, CO₂, hydrocarbons, nitrogen oxides and SO₂ are reduced so far, to residual values underneath the limit values acc. EN12021 (with series DPS..BI), respectively Pharmacopée Européenne (with series DPS..BM).

Function

For drying the compressed air, and removal of the main content of CO₂ (i.e. "adsorption"), the compressed air flow is led through a vessel filled with desiccant. The desiccant extracts moisture and CO₂ from the compressed air and stores it in its structure until the desiccant is saturated. The saturated desiccant then has to be regenerated, i.e. the moisture and CO₂ stored in the structure has to be "removed" before the desiccant can be used for drying again. Continuous operation of an adsorption dryer therefore requires two vessels that are operated alternately. One vessel is used for drying the compressed air and removal of CO₂ (adsorption) and the other vessel for regenerating the desiccant. For the DPS series, the change interval between adsorption and regeneration is 5 minutes at nominal conditions.

For the regeneration, a certain quantity of dried compressed air is drawn off at the dryer outlet (*approx. 15% of the nominal volume flow rate at nominal conditions*). This amount of compressed air is expanded to atmospheric pressure and is led through the vessel to regenerate the desiccant. The dried, decompressed air is extremely moisture-subsaturated and thus extracts the moisture stored in the desiccant and discharges it to the atmosphere via a silencer.



Product Data Sheet

Breathing Air Dryer DPS 10-100 BI and BM

Specifications subject to change without notice

Date 16.01.2024

Latest version see www.fstweb.de

The third vessel is filled with a mixture of special catalyst agent and activated carbon, and has the function to alter CO into CO₂, and afterwards to remove it besides SO₂ and the nitrogen oxides (NO_x).

Important is, that during the absorption the oxygen content remains in the stipulate tolerance acc. EN12021, (for DPS..BI), respectively Pharmacopee Europeene (for DPS..BM)

Features

The desiccant has a high drying capacity for moisture and CO₂, and a long service life. This ensures permanently low and stable pressure dew points and low CO₂ values.

The high-quality catalyst agent and the activated carbon guarantee the compliance of the prescribed remaining values for CO, CO₂, SO₂ carbon oxides and nitrogen oxides (NO_x) acc. EN12021, respectively Pharmacopee Europeene.

The valves and flow paths required for vessel chamber switch-over are completely installed in valve blocks. This integrated design eliminates the need for time-consuming piping installation and minimises the leak potential. Airflow cross-section sizes above average minimise the pressure loss.

The solenoid valve combination consists of 4 pilot-controlled diaphragm valves. Thanks to the individual control option for each valve, overlapping switch-over and a defined flow path is ensured at any time. The non-return valve combination consisting of 2 non-return valves is also installed in a leak-free aluminium valve block. A silencer is used for the effective reduction of the expansion noise.

The valves of the DPS series are controlled by means of a type "C1" processor control system with a 2-line clear text display and 3 operating keys. The control system is installed in a plastic housing with IP65 protection. The clear text display is used for direct and easy-to-understand indication of the operating state, errors, runtimes, service messages etc. If a pressure dew point sensor (option H) is connected, the current pressure dew point of the compressed air is also directly shown on the display and provided as a 4-20 mA signal. The pressure dew point measurement (option H) allows for dew-point-dependent operation of the dryer. Depending on the load of the dryer, the adsorption cycle may be extended, i.e. the switch-over frequency is adapted to the operating situation. This minimises the regeneration air consumption and thus the energy costs are minimised.

In addition, the control system provides a compressor synchronising contact. It is used for the synchronous operation of the dryer and a compressor which additionally reduces the regeneration air consumption. This function can also be used in conjunction with dew point-dependent operation.

If a differential pressure monitoring system with alarm contact is fitted to the prefilter and afterfilter (option), the alarm contacts can be connected to the control system, displayed and processed.



Product Data Sheet

Breathing Air Dryer DPS 10-100 BI and BM

Specifications subject to change without notice

Date 16.01.2024

Latest version see www.fstweb.de

As standard, the breathing air unit DPS..BI (Industrial) is provided with one pre filter (superfine filter) which prevents solid and liquid contaminants from entering the dryer. This increases the service life of the dryer.

As standard, the breathing air unit DPS..BM (Medical) is provided with two pre filters (fine- + superfine) which achieve still lower value of pollution and ensure a higher safeguarding for medical breathing air.

An afterfilter (general purpose filter) is also provided as standard on both series. It is used to prevent desiccant and or activated carbon dust from entering the downstream system. The filters are directly flanged to the upper valve block. Therefore, piping material is not required.

The breathing air units comply with the requirements of the Pressure Equipment Directive 2014/68/EU, and some (depending on the model) have the CE marking of this European directive.

Basic data

Model	Nominal volume flow (VN) ^{*1}	Min./Max. allowable operating pressure	Min./Max. allowable operating temperature
DPS 10 (A)	110 m ³ /h	4 - 16 bar	+2°C - +60°C
DPS 15 (A)	150 m ³ /h		
DPS 20 (A)	200 m ³ /h		
DPS 25 (A)	260 m ³ /h		
DPS 30 (A)	320 m ³ /h		
DPS 40 (A)	410 m ³ /h		
DPS 60 (A)	590 m ³ /h		
DPS 80 (A)	770 m ³ /h		
DPS 100 (A)	1,000 m ³ /h		

*1 - referred to 1 bar(a) and 20°C at 7 bar operating pressure, inlet temperature 35°C and pressure dew point at outlet -40°C

Volume flow conversion factors

«F1» - Pressure in bar (g)

4	5	6	7	8	9	10	11	12	13	14	15	16
0,63	0,75	0,88	1,00	1,13	1,25	1,38	1,50	1,63	1,75	1,88	2,00	2,13

«F2» - Inlet temperature in °C

25	30	35	40	45	50
1,00	1,00	1,00	0,97	0,87	0,80

Calculation of the converted volume flow

Converted volume flow VK	Nominal required volume flow VN _{min}
$VK = VN \times F1 \times F2$	$VN_{min} = VK / F1 / F2$

VK : Converted volume flow calculated for the operating conditions

VN_{min}: Nominal required volume flow calculated for the operating conditions, based on the volume flow at operating conditions

Product Data Sheet

Breathing Air Dryer DPS 10-100 BI and BM

Specifications subject to change without notice

Date 16.01.2024

Latest version see www.fstweb.de

Stipulated residual values acc. EN12021 / guaranteed residual values with DPS..BI

Contamination	Stipulated residual value acc. EN12021	Residual value with DPS..BI *2
Water content (H2O)	max. 50mg/m ³ at atmospheric pressure (equates at 10 bar(g) a pressure dew point of -25°C)	Pressure dew point -40°C (at 10 bar(g) = 10,6 mg/m ³)
Lubricants (oil)	< 0,5 mg/m ³	< 0,003 mg/m ³
Carbon dioxide (CO2)	< 500 ppm (< 500 ml/m ³)	< 150 ppm (< 150 ml/m ³)
Carbon monoxide (CO)	< 15 ppm (< 15 ml/m ³)	< 2 ppm (< 2 ml/m ³)
Oxygen content	21 ± 1 Vol. %	20,9 ± 0,2 Vol. %

Stipulated residual values acc. Pharmacopee / guaranteed residual values with DPS.BM

Contamination	Stipulated residual value acc. Pharmacopee	Residual value with DPS..BM *2
Water content (H2O)	67 ppm at atmospheric pressure (equates at 10 bar(g) a pressure dew point of -23°C)	Pressure dew point -40°C (at 10 bar(g) = 11ppm related to atmospheric pressure)
Lubricants (oil)	< 0,1 mg/m ³	< 0,003 mg/m ³
Carbon dioxide (CO2)	< 500 ppm (< 500 ml/m ³)	< 150 ppm (< 150 ml/m ³)
Carbon monoxide (CO)	< 5 ppm (< 5 ml/m ³)	< 2 ppm (< 2 ml/m ³)
Nitrogen dioxide (NO2)	< 2 ppm (< 2 ml/m ³)	< 1 ppm (< 1 ml/m ³)
Nitrogen monoxide (NO)	< 2 ppm (< 2 ml/m ³)	< 2 ppm (< 2 ml/m ³)
Nitrogen oxide (NOx)	< 1 ppm (< 1 ml/m ³)	< 1 ppm (< 1 ml/m ³)
Sulphur dioxide (SO2)	< 0,1 ppm (< 0,1 ml/m ³)	< 0,1 ppm (< 0,1 ml/m ³)
Oxygen content	20,9 ± 0,5 Vol. %	20,9 ± 0,2 Vol. %

*2 – To guarantee the residual values of CO2, CO and Oxygen, are inlet values considered as they are in our standard environment, without higher industrial pollutions :
(CO2 : 300-600 ppm, CO< 20 ppm , O2 : 20,942%)

Maintenance rules

	Maintenance interval and maintenance activities
All Models	<ul style="list-style-type: none"> ■ Once a week : <ul style="list-style-type: none"> - Check differential pressure on the prefilter and afterfilter - Check function of the condensate drain on the prefilter ■ Yearly : <ul style="list-style-type: none"> - Replace filter elements on prefilter and afterfilter - Check expansion silencer, clean or replace, if required - Calibrate dew point sensor (option H) (interchange principle possible) ■ Every 2 years: <ul style="list-style-type: none"> - Replace catalyst and activated carbon on 3rd column *3 incl. strainer and seals - Replace pilot valves and membranes of inlet and expansion valves ■ Every 4 years <ul style="list-style-type: none"> - Replace desiccant (activated Alumina F200) on first 2 columns *3 incl. strainer and seals - Replace solenoid coils ■ Pressure equipment recurrent inspection: The intervals and responsibilities for the recurrent inspections can be obtained from the valid national regulations of the respective country. It may be necessary to involve a notified body in carrying out the inspection.
	<p>*3 – The desiccant, the catalyst and the activated carbon must be disposed of according to the European waste code. A possible oil contamination must be taken into account.</p>

Product Data Sheet

Breathing Air Dryer DPS 10-100 BI and BM

Specifications subject to change without notice

Date 16.01.2024

Latest version see www.fstweb.de

Product specific data

Specification	
Pressure dew points	See page 4
Electrical connection	230V 50/60 Hz, alternative 115V 50/60Hz or 24V DC
Power consumption	< 50 Watt
Protection Class	IP 65 (Nema 4)
Valve switching power (for each valve)	20 Watt

Materials

Component	
Vessel and supports	Steel (P265GH, ST37.0, St35.8)
Coating (outside only)	sand blasted SA2,5 (ISO8501) ; 1-component primer on alkyd resin base ; dry thickness approx 40 µm (e.g. DuPont PercoTop 021, or similar product) 2-component acrylic resin paint ; dry thickness approx 40 µm (e.g. DuPont PercoTop 9600, or similar product)
Desiccant support screen	Stainless steel 304
Pipe connections (fittings)	Steel, galvanized
Valve body	Aluminium
Valve seats	Brass (Ms58), reinforced plastic
Sealing materials	HNBR
Screws	5.6 steel, zinc-plated (on valve blocks 8.8 stainless 304)
Desiccant filling	Vessel 1&2 : F200 (special activated Alumina) Vessel 3 : Carulite (catalyst) and activated carbon
Mounted prefilter and afterfilter	See product data sheets for filter housing and filter elements

Product Data Sheet

Breathing Air Dryer DPS 10-100 BI and BM

Specifications subject to change without notice

Date 16.01.2024

Latest version see www.fstweb.de

Connections, dimensions and weight (including prefilter and afterfilter)

DPS...BI

Model	Connection	Height	Width	Depth	Weight
DPS 10 BI	G 1	1460 mm	955 mm	515 mm	173 kg
DPS 15 BI	G 1	1700 mm	955 mm	515 mm	195 kg
DPS 20 BI	G 1	1720 mm	955 mm	515 mm	250 kg
DPS 25 BI	G 1	1735 mm	955 mm	515 mm	300 kg
DPS 30 BI	G 1 1/2	1830 mm	1130 mm	555 mm	350 kg
DPS 40 BI	G 1 1/2	1840 mm	1140 mm	570 mm	395 kg
DPS 60 BI	G 1 1/2	1870 mm	1200 mm	600 mm	525 kg
DPS 80 BI	G 2	2045 mm	1470 mm	715 mm	630 kg
DPS 100 BI	G 2	2060 mm	1520 mm	750 mm	740 kg

DPS..A

Model	Connection	Height	Width	Depth	Weight
DPS 10 BM	G 1	1460 mm	1085 mm	515 mm	178 kg
DPS 15 BM	G 1	1700 mm	1085 mm	515 mm	200 kg
DPS 20 BM	G 1	1720 mm	1085 mm	515 mm	255 kg
DPS 25 BM	G 1	1735 mm	1085 mm	515 mm	305 kg
DPS 30 BM	G 1 1/2	1830 mm	1260 mm	555 mm	355 kg
DPS 40 BM	G 1 1/2	1840 mm	1270 mm	570 mm	400 kg
DPS 60 BM	G 1 1/2	1870 mm	1330mm	600 mm	532 kg
DPS 80 BM	G 2	2045 mm	1635 mm	715 mm	640 kg
DPS 100 BM	G 2	2060 mm	1685 mm	750 mm	750 kg

Classification according to Pressure Equipment Directive 2014/68/EU for group 2 fluids

Model	Volume	Category
DPS 10 (A)	21 litres	II
DPS 15 (A)	26 litres	II
DPS 20 (A)	34.5 litres	II
DPS 25 (A)	44.5 litres	II
DPS 30 (A)	55.6 litres	II
DPS 40 (A)	71 litres	III
DPS 60 (A)	101 litres	III
DPS 80 (A)	132 litres	III
DPS 100 (A)	175 litres	III

Product Data Sheet

Breathing Air Dryer DPS 10-100 BI and BM

Specifications subject to change without notice

Date 16.01.2024

Latest version see www.fstweb.de

Other Directives

Model	ECM Directive 2014/30/EU	Low-voltage Directive 2014/34/EU	Machinery Directive 2006/42/EC
All Models	<p>Inspection scope for control system, solenoid valves and dew point measurement</p> <p>Emitted interference acc. :</p> <ul style="list-style-type: none"> ■ EN 55011:2009 / A1:2010 (limit value class: B) ■ EN 61000-3-2:2014 ■ EN 61000-3-3:2013 <p>Interference resistance acc.:</p> <ul style="list-style-type: none"> ■ EN 61000-6-2:2005 / AC:2005 	<ul style="list-style-type: none"> ■ EN 60204-1:2006 / A1:2009 ■ EN60730-1:2011 	is not applicable

Product Data Sheet

Breathing Air Dryer DPS 10-100 BI and BM

Specifications subject to change without notice

Date 16.01.2024

Latest version see www.fstweb.de

Flow diagram (PID)

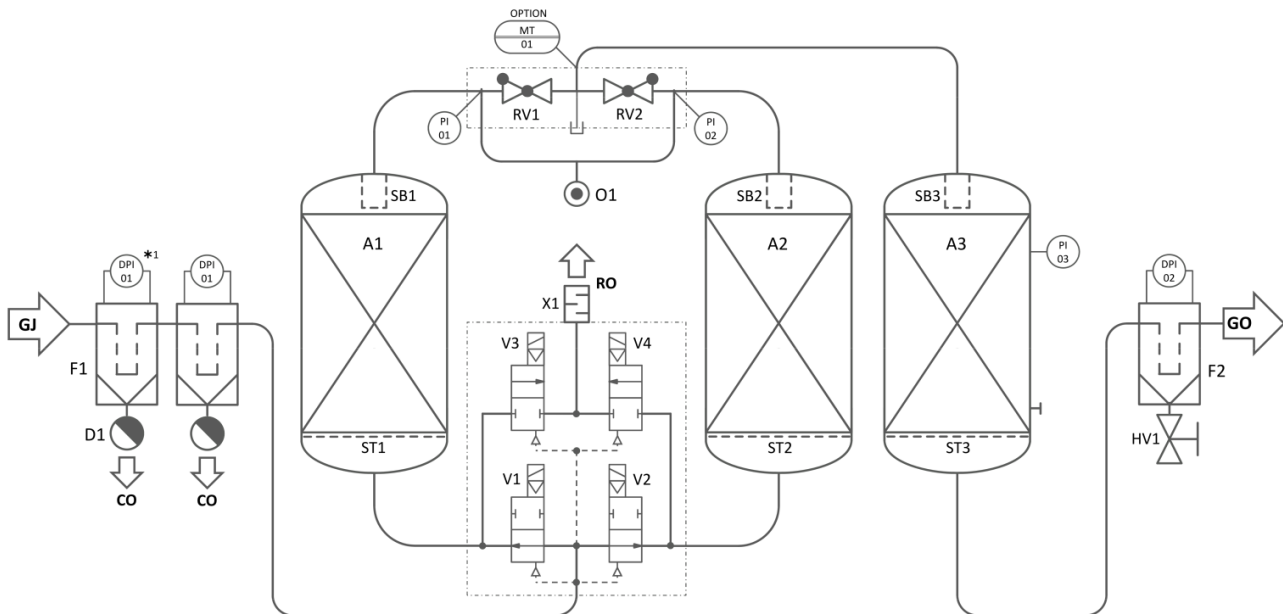

*1 : 2nd prefilter only for DPS..BM

- A 1+2** Dryer vessel
- A 3** Purifier vessel
- F** Filter
- V** Valve
- HV** Manual valve
- RV** Non return valve
- SB** Sleeve cylinder
- ST** Support screen
- X** Silencer for expansion
- D** Condensate drain
- O** Orifice for regeneration air flow
- PI** Pressure gauge
- DPI** Differential pressure gauge
- MT** Pressure dew point transmitter

- GJ** Gas inlet
- GO** Gas outlet
- RO** Regeneration air outlet
- CO** Condensate outlet

Product Data Sheet

Breathing Air Dryer DPS 10-100 BI and BM

Accessories



The DA-CM1-230 switch-over control system enables the control of two redundant compressed air dryers in a compressed air system. The two dryers can be operated alternately while switching over automatically. All dryers, provided with a «remote start/stop contact» or a «compressor synchronisation contact», can be directly connected to the switch-over control system without the need for any further modifications. The DA-CM1-230 also controls all required shut-off valves (no scope of supply) to open or close the compressed air line to a dryer (e.g. solenoid valves or valves with an actuating drive for 230V AC supply voltage). Furthermore, additional input signals can be hooked up to the common alarm message of each dryer. Beside the power supply, the DA-CM1-230 provides alarm inputs for condensate drains, differential pressure gauges, etc. for each dryer.

The GSM Module DA-ETR-107 is an easy-to-install extension for all dryers with alarm contact. In case of an alarm, a SMS message is sent to up to 6 different recipients or, if supported by the provider, an email message. Within the message, the dryer type and serial number is transferred, if required.

The programming can be done with a usual mobile phone, protected by the PIN code of the SIM card (no scope of supply) applied to the GSM module. The DA-ETR-107 is operated with 5-32V DC supply voltage. An internal battery ensures operation of up to 120 hours in case of loss of the supply voltage. The GSM module has an integrated antenna while an external antenna can be connected in the case of low signal levels.



The Start-up device (minimum pressure valve) DA-VPM-... protects the dryer from overload due to high flow velocities during pressure build-up of the compressed air system. For connection size G ½ to G 2½ spring loaded angle valves are offered (DA-VPM-B../16), providing an opening pressure of 3-5 bar (standard 3.5 bar). For connection size DN80 to DN250 butterfly valves with pneumatic actuator are offered (DA-VPM-F../11), directly operated by the working pressure while opening at 3 bar (full cross-section at 4 bar). Special versions with adjustable opening pressure or working pressures of up to 450 bar are available on request.



Differential pressure gauges FAD01C with potential free alarm contact allow to hook up the differential pressure control of the pre- and after-filter to the common alarm message of each dryer. To avoid a false error report due to start-up conditions or short-time peaks, an alarm delay can be set in the dryer control unit. The alarm message then will just be generated, if a too high differential pressure was indicated during the entire delay time interval.

... and many more. Please contact us.