

# Product Data Sheet

## Adsorption Dryer DTS..BP

Version: 1.8.1

Author: Tassilo Tappe

Date: 01.03.2023

### Field of application

Adsorption dryers of the DTS..BP series are designed for drying compressed air and nitrogen to pressure dew points of  $-25^{\circ}\text{C}$  to  $-70^{\circ}\text{C}$  (depending on the design) at operating pressures of 4 bar to 11 bar (up to 63 bar on request).

### Function

Adsorption dryers consist of two pressure vessels, which are both filled with desiccant and are alternately operated via switch-over. The compressed air to be dried flows through a vessel where the moisture is thoroughly removed by the desiccant (**adsorption**). At the same time, the moisture stored in the desiccant in the second vessel is removed (**regeneration**). If the desiccant in the vessel in which adsorption takes place is saturated with moisture then the vessels are switched and the process begins again. One complete run of adsorption and regeneration in a vessel is called a **cycle**, and the time required is the **cycle time**.

For DTS series dryers, the change interval between adsorption and regeneration is 6 hours at nominal conditions. The cycle time is therefore 12 hours.

The regeneration takes place with ambient air, which is drawn in by a blower, heated in an electric heater and fed through the desiccant (heating). The hot air removes the moisture from the desiccant and releases it to the environment at the outlet (heat regeneration).

Cooling is carried out by air certain amount of dried, expanded air (2- 3 % purge air in average).

Further energy savings can be made through integration of the customer's alternative energy sources (e.g. steam or hot water) and/or thermal insulation.



# Product Data Sheet

## Adsorption Dryer DTS..BP

### Features

The dryers are operated with a 2-layer desiccant bed, consisting of 30% water resistant silica gel WS and 70% high-grade drying silica gel N. The desiccant has a high drying capacity for moisture and a long service life of several years. This ensures permanently low and stable pressure dew points.

The flow paths are switched over via pneumatically controlled 4/2-way plug valves, which are mechanically connected to each other via a cardan shaft and therefore switch in synch. Model DTS 1280 and higher uses shut-off valves with end position control. The expansion (before starting regeneration) and the pressurisation (after the regeneration) are carried out via separately controlled pneumatic actuated seat angle valves. At the expansion outlet a silencer is used for effective reduction of the expansion noise.

For this dryer size the filters are not included in the scope of supply of the dryer. But pre filters (fine filters) that prevent solid particles ( $< 0.01 \mu\text{m}$ ) and liquid contaminants ( $< 0.01 \text{ mg/m}^3$ ) from entering should be installed upstream of the dryers in order to increase the service life of the desiccant. An afterfilter (general purpose filter) should be installed downstream of the dryer in order to prevent possible desiccant dust ( $< 1 \mu\text{m}$ ) from entering.

The dryers comply with the requirements of the Pressure Equipment Directive 2014/68/EU, and have the CE marking of this European directive.



# Product Data Sheet

## Adsorption Dryer DTS..BP

Specifications subject to change without notice

Date 01.03.2023

Latest version see [www.fstweb.de](http://www.fstweb.de)

### Features of the controller „C10“

The function of the DTS series are controlled by means of a type "C10" processor control system with a 5,7" (640x480 Pixel) colour touch panel. The operation is shown on the display via flow diagram with all operating data.

Via text indicator all operating messages, alarm messages, operating hour counter, service messages are shown in plain manner.

If a pressure dew point sensor (option H) is connected, the current pressure dew point of the compressed air is also directly shown on the display and provided as a 4-20 mA signal. The pressure dew point measurement (option H) allows for dew-point dependent operation of the dryer. Depending on the load of the dryer, the adsorption cycle may be extended, i.e. the switch-over frequency is adapted to the operating situation, and less frequently heating up the system saves energy costs.

The control covers a multiplicity of monitoring criteria and safety chains. 25 different error messages and 15 different warnings can be evaluated.

All operating data (temperatures, pressures, dew-point) are recorded every minute, and saved in a circular buffer, which always has the last 2 months recording in memory. Via USB-Host the data can be downloaded at any time.

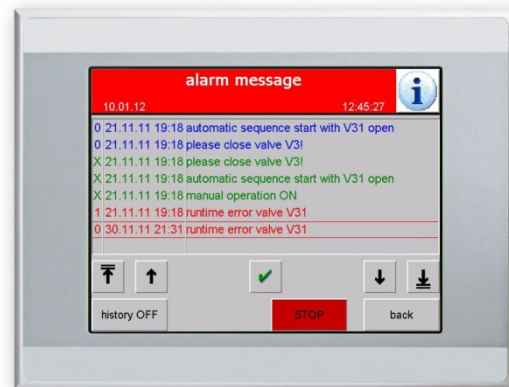
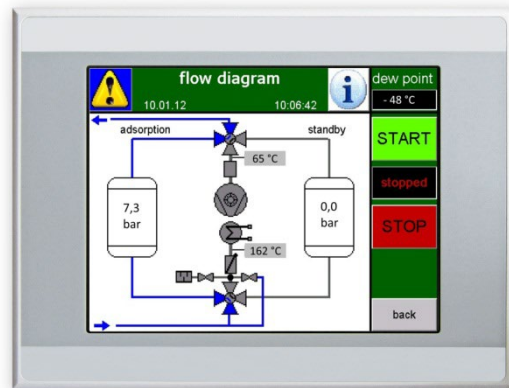

# Product Data Sheet

## Adsorption Dryer DTS..BP

### Technical Data of the controller „C10“

- 5,7" TFT colour display (Resolution VGA 640x480 ) , 64 colours, LED backlight, dimmable via software
- Resistive touch screen (reacted to pressure and is thus operable with the finger and electronic pen)
- Power supply 19,2 ..30,0 VDC effective ( nominal 24VDC SEL V )
- Protection class IP65 ( in installed condition )
- Operating system WinCE 5.0 Core
- Processor 32 Bit RISC, 400MHz
- With real time clock
- Memory DDR RAM 64 MB + retain memory NVRAM 32kB + flash memory NAND Flash 128 MB
- Download-interface (Trend recording download) via USB-Host
- Upload-interface (Program-Upgrade) via SD Memory card

### Input signals of controller „C10“

- PT01 – Pressure vessel 1 (4-20mA)
- PT02 – Pressure vessel 2 (4-20mA)
- TT01 – Temperature Regeneration air inlet (PT100)
- TT02 – Temperature Regeneration air outlet (PT100)
- MT01 – Pressure dew point (optional, 4-20 mA)
- TSH01 – Limiter thermostat heater
- GS03 – Limit switches for position of regeneration air valve
- GS01 – Limit switches for position of main valves (optional)

### Output signals and interfaces of controller „C10“

- 2 voltage free contacts (operating message and common alarm)
- 2 analog signals 4-20 mA (pressure dew point and operating pressure)
- USB Host for downloading the trend recording
- **OPTIONAL** : Profibus, Modbus, CANbus, Ethernet, ... and many more

# Product Data Sheet

## Adsorption Dryer DTS..BP

Specifications subject to change without notice

Date 01.03.2023

Latest version see [www.fstweb.de](http://www.fstweb.de)

### Basic data

Model	Nominal volume flow (VN) <sup>*1.1</sup>	Min./Max. allowable operating pressure	Min./Max. allowable operating temperature
DTS 45 BP	410 m <sup>3</sup> /h	4 - 11 bar <sup>*1.2</sup>	+2°C - +50°C <sup>*1.3</sup>
DTS 55 BP	500 m <sup>3</sup> /h		
DTS 65 BP	645 m <sup>3</sup> /h		
DTS 85 BP	790 m <sup>3</sup> /h		
DTS 125 BP	1.210 m <sup>3</sup> /h		
DTS 155 BP	1.490 m <sup>3</sup> /h		
DTS 215 BP	2.100 m <sup>3</sup> /h		
DTS 250 BP	2.440 m <sup>3</sup> /h		
DTS 300 BP	2.950 m <sup>3</sup> /h		
DTS 380 BP	3.750 m <sup>3</sup> /h		
DTS 430 BP	4.250 m <sup>3</sup> /h		
DTS 500 BP	4.930 m <sup>3</sup> /h		
DTS 540 BP	5.330 m <sup>3</sup> /h		
DTS 650 BP	6.510 m <sup>3</sup> /h		
DTS 720 BP	7.180 m <sup>3</sup> /h		
DTS 860 BP	8.600 m <sup>3</sup> /h		
DTS 940 BP	9.400 m <sup>3</sup> /h		
DTS 1110 BP	11.000 m <sup>3</sup> /h		
DTS 1280 BP	12.800 m <sup>3</sup> /h		
DTS 1470 BP	14.700 m <sup>3</sup> /h		

\*1.1 - referred to 1 bar(a) and 20°C at 7 bar operating pressure, inlet temperature 35°C and pressure dew point at outlet -40°C

\*1.2 – higher operating pressures on request

\*1.3 – the max. compressed air inlet temperature depends on the operating pressure – even lower the operating pressure, the lower may be the allowed inlet temperature

### Purity classes according to ISO 8573-1

Contamination	
Solid particles	---
Water content	class 1-3 <sup>*2</sup>
Total oil content	---

\*2 depending on the design of pressure dew point

# Product Data Sheet

## Adsorption Dryer DTS..BP

Specifications subject to change without notice

Date 01.03.2023

Latest version see [www.fstweb.de](http://www.fstweb.de)

### Volume flow conversion factors

«F» - Compressed air inlet temperature in °C and inlet pressure in bar (g) for pressure dew point -40°C

°C \ bar (g)	4*3	5	6	7	8	9	10	11	12*4	13*4	14*4	15*4	16*4
25,0	0,65	0,76	0,89	1,02	1,10	1,17	1,25	1,31	1,37	1,41	1,50	1,53	1,57
30,0	0,65	0,76	0,89	1,02	1,10	1,17	1,23	1,30	1,36	1,41	1,49	1,52	1,56
<b>35,0</b>	0,50	0,66	0,83	<b>1,00</b>	1,08	1,15	1,21	1,27	1,33	1,39	1,48	1,50	1,55
37,5	0,39	0,53	0,68	0,83	0,98	1,09	1,19	1,26	1,32	1,38	1,44	1,48	1,54
40,0	---	0,42	0,56	0,70	0,82	0,94	1,04	1,13	1,24	1,33	1,42	1,47	1,53
42,5	---	---	0,41	0,52	0,66	0,77	0,82	0,99	1,07	1,16	1,24	1,33	1,40
45,0	---	---	---	---	---	---	---	0,88	0,95	1,02	1,10	1,17	1,23

\*3 – for operating pressures lower than 4 bar(g) an external control air supply > 4 bar(g) needs to be provided

\*4 – Dryers with operating pressure > 11 bar (g) on request

### Calculation of the converted volume flow

Converted volume flow VK	Nominal required volume flow $VN_{min}$
$VK = VN \times F$	$VN_{min} = VK / F$

VK : Converted volume flow calculated for the operating conditions

$VN_{min}$ : Nominal required volume flow calculated for the operating conditions, based on the volume flow at operating conditions

*Please contact the technical support team for a professional sizing of the dryer*

### Maintenance rules

	Maintenance interval and maintenance activities
All Models	<ul style="list-style-type: none"> <li>■ Once a week :               <ul style="list-style-type: none"> <li>- Check differential pressure of prefilter if installed</li> <li>- Check function of the condensate drains at prefilter if installed</li> </ul> </li> <li>■ yearly :               <ul style="list-style-type: none"> <li>- Replace filter elements on prefilter and afterfilter if installed</li> <li>- Check expansion silencer, clean or replace, if required</li> <li>- Calibrate dew point sensor (option H) (interchange principle possible)</li> </ul> </li> <li>■ Every 2 years:               <ul style="list-style-type: none"> <li>- Replace solenoid valves (pilot valves)</li> </ul> </li> <li>■ Every 4 years:               <ul style="list-style-type: none"> <li>- Replace desiccant, sleeve cylinder and seals *7 *8</li> </ul> </li> <li>■ Every 5 /10 years               <ul style="list-style-type: none"> <li>- Pressure vessel inspection acc. to Ordinance on Industrial Safety and Health of September 27th, 2002 (BGBl. I p. 3777) §15,</li> <li>- Inside check every 5 years</li> <li>- Strength test (hydrostatic) every 10 years, both carried out by an authorised inspection agency, see page 9</li> </ul> </li> </ul>

\*5 – The regular service life of the desiccant is 3 - 5 years, however, it is very much depending on the contamination level of the incoming compressed air and the operating temperature. In order to achieve the specified service life of the desiccant, it is vital to exchange the filter elements as described above.

\*6 – The desiccant and the activated carbon must be disposed of according to the European waste code. A possible oil contamination must be taken into account.

# Product Data Sheet

## Adsorption Dryer DTS..BP

Specifications subject to change without notice

Date 01.03.2023

Latest version see [www.fstweb.de](http://www.fstweb.de)

### Product specific data

Specification	
Pressure dew points	-25°C / -40°C / -70°C*7

\*7 – for pressure dew points of -70°C and installations where the vessels are exposed to air streams a heat insulation is recommended (Option)

### Materials

Component	
Vessel and supports	carbon steel (P265GH, ST37.0, St35.8)
Coating	<p><u>inside</u> : 1/3 lower part of the vessels painted with "Brantho Korrux"</p> <p><u>outside</u>: sand blasted SA2,5 (ISO8501) ;</p> <p>1-component primer on alkyd resin base ; dry thickness approx 40 µm (e.g. DuPont PercoTop 021, or similar product)</p> <p>2-component acrylic resin paint ; dry thickness approx 40 µm (e.g. DuPont PercoTop 9600, or similar product)</p>
Desiccant support screen	stainless steel 1.4301
Pipe work	carbon steel, galvanised
Main valves	Housing GGG40, ball / plug 1.4408 – Design Temp. -40 up to +240°C
Reg.-Air-butterfly valve DN 40 : K11-6666S size > DN50 : KG9-2266S	Housing GG25, butterfly up to DN150 1.4581, DN200 1.4408, sealing MVQ (silicon) pneumatic actuator : housing Aluminium Hart-coat Design Temp. -30 up to +220°C
Angle seat valve for Expansion and Pressurisation	Housing GG25, plug 1.4408, shaft 1.4401, sealing EPDM Design Temp. -40 up to +150°C
Sealing materials	HNBR, IFG5500
Screws	5.6, galvanised
Desiccant filling	100% Silicagel

# Product Data Sheet

## Adsorption Dryer DTS..BP

Specifications subject to change without notice

Date 01.03.2023

Latest version see [www.fstweb.de](http://www.fstweb.de)

### Electrical data

Model	Power supply	Installed power *8	average power consumption *9	max. current draw	Recommended cable size*10	Recommended fuse protection
DTS 45 BP	400 V / 50Hz  other voltages & frequency on request	5,5 kW	4,1 kWh/h	8,9 A	3x 4mm <sup>2</sup> + 4mm <sup>2</sup>	3x 16 A
DTS 55 BP		5,5 kW	5,0 kWh/h	8,9 A	3x 4mm <sup>2</sup> + 4mm <sup>2</sup>	3x 16 A
DTS 65 BP		9,7 kW	6,4 kWh/h	16,5 A	3x 6mm <sup>2</sup> + 6mm <sup>2</sup>	3x 25 A
DTS 85 BP		9,7 kW	7,7 kWh/h	16,5 A	3x 6mm <sup>2</sup> + 6mm <sup>2</sup>	3x 25 A
DTS 125 BP		13,4 kW	11,1 kWh/h	21,5 A	3x 10mm <sup>2</sup> + 10mm <sup>2</sup>	3x 25 A
DTS 155 BP		18,2 kW	14,6 kWh/h	29,7 A	3x 10mm <sup>2</sup> + 10mm <sup>2</sup>	3x 32 A
DTS 215 BP		22,2 kW	19,0 kWh/h	35,5 A	3x 16mm <sup>2</sup> + 16mm <sup>2</sup>	3x 50 A
DTS 250 BP		36,7 kW	22,4 kWh/h	58,6 A	3x 35mm <sup>2</sup> + 35mm <sup>2</sup>	3x 80 A
DTS 300 BP		36,7 kW	27,0 kWh/h	58,6 A	3x 35mm <sup>2</sup> + 35mm <sup>2</sup>	3x 80 A
DTS 380 BP		43,7 kW	34,7 kWh/h	68,7 A	3x 35mm <sup>2</sup> + 35mm <sup>2</sup>	3x 80 A
DTS 430 BP		48,7 kW	38,6 kWh/h	76,0 A	3x 35mm <sup>2</sup> + 35mm <sup>2</sup>	3x 100 A
DTS 500 BP		48,7 kW	45,1 kWh/h	76,0 A	3x 35mm <sup>2</sup> + 35mm <sup>2</sup>	3x 100 A
DTS 540 BP		73,2 kW	49,4 kWh/h	117,7 A	3x 50mm <sup>2</sup> + 50mm <sup>2</sup>	3x 150 A
DTS 650 BP		73,2 kW	60,1 kWh/h	117,7 A	3x 50mm <sup>2</sup> + 50mm <sup>2</sup>	3x 150 A
DTS 720 BP		84,2 kW	66,1 kWh/h	133,7 A	3x 70mm <sup>2</sup> + 70mm <sup>2</sup>	3x 150 A
DTS 860 BP		102,7 kW	77,1 kWh/h	152,7 A	3x 95mm <sup>2</sup> + 95mm <sup>2</sup>	3x 200 A
DTS 940 BP		102,7 kW	84,2 kWh/h	152,7 A	3x 95mm <sup>2</sup> + 95mm <sup>2</sup>	3x 200 A
DTS 1110 BP		125,2 kW	100,5 kWh/h	189,2 A	3x 95mm <sup>2</sup> + 95mm <sup>2</sup>	3x 250 A
DTS 1280 BP		144,2 kW	116,7 kWh/h	216,6 A	3x 120mm <sup>2</sup> + 120mm <sup>2</sup>	3x 250 A
DTS 1470 BP		165,2 kW	133,8 kWh/h	241,3 A	3x 120mm <sup>2</sup> + 120mm <sup>2</sup>	3x 315 A

\*8 – at power supply 400 V / 50Hz

\*9 – at nominal volume flow referred to 1 bar(a) and 20°C at 7 bar operating pressure, inlet temperature 35°C and pressure dew point at outlet -40°C, 25°C ambient temperature 25°C, 100m above sea level (=1000mbar ambient pressure) and 50% rel. humidity, and dew point dependent cycle.

\*10 – The recommended cable sizes are referred to 400V /50Hz, copper cable with approx. 100 m length, and PVC cable coating for max. 70°C, used at of 40°C, acc. EN 60204. Local regulations remain applicable if they are stricter than the values proposed.  
The voltage drop must not exceed 3 % of the nominal voltage. It may be necessary to use cables with larger size than those to comply with this requirement.

Specifications	
Protection class	IP54
Motors	The motors of the vacuum pumps are according to EN 60034 / DIN IEC34-1, Isolation class F Voltage tolerance ±10%, Frequency tolerance ±5%
Pressure sensors	Two-wire-system, measuring range 0-16 bar, Output signal 4-20 mA
Temperature sensors	PT 100: measuring range 0-300 °C
Pressure dew point sensor (Option)	Two-wire-system, measuring range -100 - +20 °C, Output signal 4-20 mA



# Product Data Sheet

## Adsorption Dryer DTS..BP

Specifications subject to change without notice

Date 01.03.2023

Latest version see [www.fstweb.de](http://www.fstweb.de)

### Connections, dimensions and weight

Model	Connection Air In-& Outlet	Height	Width	Depth	Weight
DTS 45 BP	DN 40 – PN16	2225 mm	1190 mm	1000 mm	530 kg
DTS 55 BP	DN 40 – PN16	2225 mm	1190 mm	1000 mm	560 kg
DTS 65 BP	DN 50 – PN16	2325 mm	1310 mm	1085 mm	740 kg
DTS 85 BP	DN 50 – PN16	2325 mm	1310 mm	1085 mm	790 kg
DTS 125 BP	DN 80 – PN16	2705 mm	1460 mm	1150 mm	1150 kg
DTS 155 BP	DN 80 – PN16	2720 mm	1510 mm	1230 mm	1350 kg
DTS 215 BP	DN 80 – PN16	2770 mm	1600 mm	1460 mm	1650 kg
DTS 250 BP	DN 100 – PN16	2885 mm	2020 mm	1475 mm	1800 kg
DTS 300 BP	DN 100 – PN16	2920 mm	2050 mm	1505 mm	2400 kg
DTS 380 BP	DN 100 – PN16	2970 mm	2160 mm	1590 mm	2850 kg
DTS 430 BP	DN 150 – PN16	3210 mm	2370 mm	1560 mm	3900 kg
DTS 500 BP	DN 150 – PN16	3235 mm	2475 mm	1745 mm	4050 kg
DTS 540 BP	DN 150 – PN16	3250 mm	2520 mm	1870 mm	4250 kg
DTS 650 BP	DN 150 – PN16	3520 mm	2520 mm	1920 mm	5000 kg
DTS 720 BP	DN 150 – PN16	3560 mm	2640 mm	1985 mm	5650 kg
DTS 860 BP	DN 200 – PN16	3590 mm	4400 mm	1995 mm	6400 kg
DTS 940 BP	DN 200 – PN16	3610 mm	4500 mm	1995 mm	7500 kg
DTS 1110 BP	DN 200 – PN16	3650 mm	4750 mm	1995 mm	8750 kg
DTS 1280 BP	DN 200 – PN16	4050 mm	4950 mm	2030 mm	10700 kg
DTS 1470 BP	DN 200 – PN16	4050 mm	5150 mm	2055 mm	12500 kg

# Product Data Sheet

## Adsorption Dryer DTS..BP

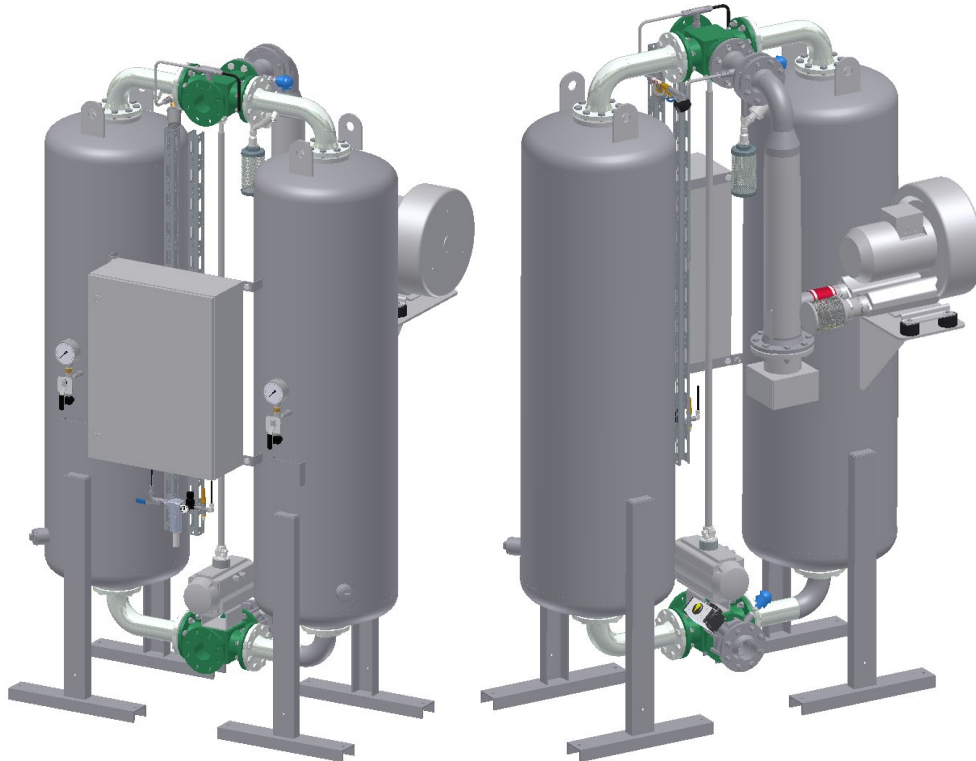

DTS 45 BP - DTS 1900 BP

# Product Data Sheet

## Adsorption Dryer DTS..BP

Specifications subject to change without notice

Date 01.03.2023

Latest version see [www.fstweb.de](http://www.fstweb.de)

### Classification according to Pressure Equipment Directive 2014/68/EU for group 2 fluids

Model	Volume	Category	Marking
DTS 45 BP	125 Litres	III	CE 0525
DTS 55 BP	125 Litres		
DTS 65 BP	202 Litres		
DTS 85 BP	202 Litres		
DTS 125 BP	305 Litres	IV	
DTS 155 BP	376 Litres		
DTS 215 BP	530 Litres		
DTS 250 BP	627 Litres		
DTS 300 BP	760 Litres		
DTS 380 BP	980 Litres		
DTS 430 BP	1115 Litres		
DTS 500 BP	1300 Litres		
DTS 540 BP	1420 Litres		
DTS 650 BP	1770 Litres		
DTS 720 BP	1965 Litres		
DTS 860 BP	2400 Litres		
DTS 940 BP	2650 Litres		
DTS 1110 BP	3085 Litres		
DTS 1280 BP	3650 Litres		
DTS 1470 BP	4250 Litres		

### Other Directives

Model	
All Models	<p>Execution of control with EEC conformity, related to :</p> <p>Low voltage switchgear acc. EN 60439-1 (VDE0660 Teil500)</p> <p>Safety of machinery / Electrical equipment of machines acc. DIN EN60204-1 (VDE0113-1:2007-06) and DIN EN60204-1/A1 (VDE0113-1/A1:2009-10)</p> <p>Electrical equipment for use within certain voltage limits acc. 2006/95/EG</p> <p>EMC standard acc. 2014/30/EU</p>

# Product Data Sheet

## Adsorption Dryer DTS..BP

Specifications subject to change without notice

Date 01.03.2023

Latest version see [www.fstweb.de](http://www.fstweb.de)

### Flow diagram (PID) – DTS 45-1110 BP

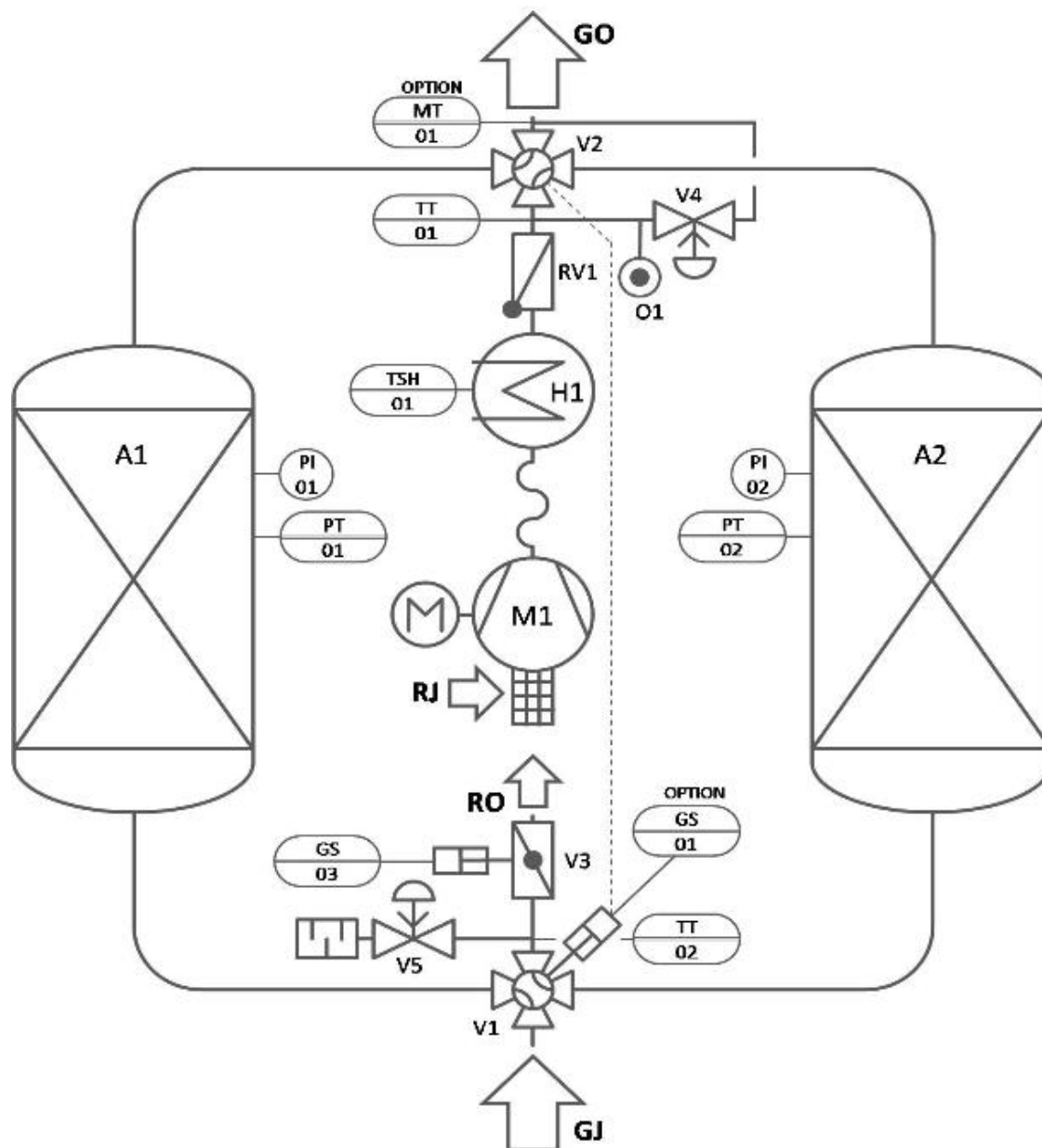

<b>A</b>	Dryer vessel
<b>ST</b>	Desiccant support screen
<b>SB</b>	Dust sleeve cylinder
<b>V</b>	Valve
<b>RV</b>	Non return valve
<b>H</b>	Heater
<b>X</b>	Silencer
<b>SG</b>	Suction grid
<b>GS</b>	Limit switch
<b>TT</b>	Temperature-Transmitter

<b>TSH</b>	Temperature-Limiter
<b>PI</b>	Pressure gauge
<b>PT</b>	Pressure transmitter
<b>MT</b>	Dew point transmitter
<b>GJ</b>	Gas Inlet
<b>GO</b>	Gas Outlet
<b>RJ</b>	Regeneration gas Inlet
<b>RO</b>	Regeneration gas Outlet

# Product Data Sheet

## Adsorption Dryer DTS..BP



Specifications subject to change without notice

Date 01.03.2023

Latest version see [www.fstweb.de](http://www.fstweb.de)

### Notes

# Product Data Sheet

## Adsorption Dryer DTS..BP

### Accessories



**The DA-CM1-230 switch-over control system** enables the control of two redundant compressed air dryers in a compressed air system. The two dryers can be operated alternately while switching-over automatically. All dryers, provided with a «remote start/stop contact» or a «compressor synchronisation contact», can be directly connected to the switch-over control system without the need for any further modifications. The DA-CM1-230 also controls all required shut-off valves (no scope of supply) to open or close the compressed air line to a dryer (e.g. solenoid valves or valves with actuating drive for 230V AC supply voltage). Furthermore, additional input signals can be hooked up to the common alarm message of each dryer. Beside the power supply the DA-CM1-230 provides alarm inputs for condensate drains, differential pressure gauges, etc. for each dryer.

**The GSM Module DA-ETR-107** is an easy to install extension for all dryers with alarm contact. In case of an alarm a SMS message is send to up to 6 different recipients or, if supported by the provider, an email message. Within the message, the dryer type and serial number is transferred, if required.

The programming can be done with a usual mobile phone, protected by the PIN code of the SIM card (no scope of supply) applied to the GSM module. The DA-ETR-107 is operated with 5-32V DC supply voltage. An internal battery ensures operation of up to 120 hours in case of loss of the supply voltage. The GSM module has an integrated antenna while an external antenna can be connected in the case of low signal levels.



**The Start-up device (minimum pressure valve) DA-VPM-...** protects the dryer from overload due to high flow velocities during pressure build-up of the compressed air system. For connection size G ½ to G 2½ spring loaded angle valves are offered (DA-VPM-B../16), providing an opening pressure of 3-5 bar (standard 3.5 bar). For connection size DN80 to DN250 butterfly valves with pneumatic actuator are offered (DA-VPM-F../11), directly operated by the working pressure while opening at 3 bar (full cross-section at 4 bar). Special versions with adjustable opening pressure or working pressures of up to 450 bar are available on request.



**Differential pressure gauges FAD01C with potential free alarm contact** allow to hook up the differential pressure control of the pre- and after-filter to the common alarm message of each dryer. In order to avoid a false error report due to start-up conditions or short-time peaks, an alarm delay can be set in the dryer control unit. The alarm message then will just be generated, if a too high differential pressure was indicated during the entire delay time interval.

... and many more. Please contact us.