

Operating Manual  
Adsorber  
DSS 1-8 A

Version: 02/2016/EN





# Inhaltsverzeichnis

---

1.	General Information .....	5
1.1	Manufacturer.....	5
1.2	Adsorber data .....	6
1.3	Contact data .....	6
1.4	Additional documents .....	6
1.5	Warranty notes.....	7
1.6	About this operating manual.....	7
2.	Description of application .....	9
2.1	Intended use.....	9
2.2	Technical data.....	11
3.	Safety notes .....	12
3.1	Signs and instructions.....	12
3.2	Danger zones at the adsorber .....	13
3.3	General safety notes.....	14
4.	Technical product description .....	16
4.1	Assembly drawing.....	16
4.2	Process diagram.....	17
4.3	Function description.....	18
4.4	Options .....	19
5.	Operating elements.....	19
5.1	Oil indicator .....	19
6.	Transportation, setting up and storage.....	20
6.1	Transportation.....	20
6.2	Setting up.....	21
6.3	Storage.....	22
7.	Installation.....	23
7.1	Installing the connecting pipelines.....	23
8.	Commissioning .....	25
8.1	Requirements for initial commissioning.....	25
8.2	Commissioning the adsorber.....	26
8.2.1	Pressurisation of the adsorber .....	26
8.2.2	Opening the outlet valve .....	27
9.	Shutting down and restarting the adsorber .....	28
9.1	Shutting down the adsorber.....	28
9.2	Depressurising the adsorber .....	28
9.3	Restarting the adsorber.....	28
10.	Maintenance and repair .....	29
10.1	Regular maintenance intervals.....	30
10.1.1	Visual check and function monitoring.....	30
10.1.2	Cleaning the adsorber .....	30
10.1.3	Determining the residual oil content in the compressed air.....	31
10.1.4	Replacing indicator tube.....	32
10.1.5	Checking and replacing the granulate / Cleaning the strainer basket .....	33
10.1.6	Replacing filter elements (Option) .....	35

---

11. Faults and measures .....	36
12. Appendix and technical documents .....	38
12.1 Manufacturer's declaration .....	38
12.2 Declaration of conformity .....	39
12.3 Tables for oil indicator .....	40
12.3.1 $\geq 7$ bar (g).....	40
12.3.2 6 bar (g).....	41
12.3.3 5 bar (g).....	42
12.3.4 4 bar (g).....	43
12.4 General arrangement drawing .....	44



## 1. General Information

### 1.1 Manufacturer



FST GmbH

Head office: Weiherdamm 17 – 57250 Netphen, Germany

Sales office: Im Teelbruch 106 – 45219 Essen, Germany

☎ +49 (0) 2054 8735-0

📠 +49 (0) 2054 8735-100

✉ info@fstweb.de

***! For any questions about the product, please contact the sales office !***

In case of questions about the product, please specify the type and the manufacturing number. This information can be found on the type plate of the adsorber. (→Page 12)

# General Information

---

## 1.2 Adsorber data

Model:	
Order no.:	
Manufacturing no.:	
Vessel no. (left/right):	
Year of manufacture:	
Date of commissioning:	

## 1.3 Contact data

Name:	
Company:	
Address:	
Phone / Fax:	
E-mail:	

The above adsorber data differs for each adsorber. Please fill in the fields according to the type plate and your contract documents. This data enables the manufacturer to clearly identify the adsorber and simplifies service and provision of the proper spare parts.

Some of the information listed here and other important data can be found on the type plate of the adsorber and on the type plate of the vessels. (→Page 12)

## 1.4 Additional documents

- General arrangement drawing
- Manufacturers declaration or declaration of conformity

## 1.5 Warranty notes

For warranty information, please refer to our "General Terms of Sale and Delivery".

(→ [www.fstweb.de](http://www.fstweb.de))

In the following cases the warranty shall be void:

- If the safety notes and instructions of this operating manual and of the additional documents are not observed.
- If the adsorber is operated or maintained by personnel who do not have the required qualifications. (→ see "Target group": (→Page 7)
- If the adsorber is used for anything other than its intended use. (→ Page 9)
- If aggressive substances in the compressed air or ambient air cause damage to the adsorber.
- If parts other than genuine parts of the manufacturer have been used for maintenance and repair.
- If the adsorber is operated although defects are evident.

## 1.6 About this operating manual

This operating manual contains all the technical information required for installation, operation, maintenance and disposal of the adsorber.

### Target group

This operating manual is directed to all persons working on and with the adsorber. We point out that these persons have to be qualified personnel who, because of their qualification and experience, are familiar with handling compressed air systems. If you are not experienced in using these systems, please ask the relevant experts for help. We highly recommend that commissioning and maintenance be carried out by the manufacturer or one of the authorised service partners.

### Using the operating manual

Please read the operating manual and the additional documents carefully prior to installation and follow the notes and instructions. Safe and proper operation of the adsorber can only be guaranteed if the instructions and notes are observed. The safety notes must be observed in particular.

The operating manual must be kept in the vicinity of the adsorber and must be easily accessible.

When selling or hiring out the adsorber, also provide this operating manual and all the additional documents to the new user. (→ Page 6)

The manufacturer accepts no liability for damages resulting from disregard of the operating manual.

All the information in this operating manual is valid at the time the manual is published. Due to component or workflow modifications at any time affecting adsorber maintenance, the latest information should be available prior to maintenance work.

# General Information

---

## Signs and symbols used

- Boxes are used for bulleted lists.
- 1) Enumerated lists point out that the working steps are to be carried out in a specified order.
- Cross references refer to information on a different page or in a different document.



### Note!

This symbol refers to matters that should be given special attention. Observing the notes helps to ensure safe handling of the product.



### Tips and hints!

This symbol refers to matters that should be given special attention. Observing these advisory notes helps to ensure particular efficient operation of the product.



### CAUTION !

This symbol indicates a possible harmful situation. When not avoiding this situation, there is a danger of injury or damage to the product or to adjacent system components.



### WARNING !

This symbol indicates a possible dangerous situation. When not avoiding this situation, there is a danger of serious injury or death.



### DANGER !

This symbol indicates an immediate impending danger. Not avoiding this danger results in serious injury or death.



## 2. Description of application

The adsorber is used to remove oil vapour, smells and gustatory substances from compressed air for industrial use.

Typically, the adsorber is used for purifying compressed air from a compressor station.

During pre-treatment of the compressed air by means of separators, fine filters and dryers only solid particles, liquids and water vapour can be removed from the compressed air. After this pre-treatment the adsorber also removes the vaporous oil components as well as many smells and gustatory substances. The compressed air is purified until only a very low residual content of these substances remains in the compressed air.

The adsorber can remove a wide range of non-polar, long chain hydrocarbons from the compressed air flow. Compressor oil is adsorbed by the granulate particularly well.

Polar substances or hydrocarbons with low carbon content (e.g. methane, ethane, etc.) are adsorbed to a lesser degree or are hardly adsorbed at all.

In case of doubt, please contact the manufacturer to evaluate your application and to find a suitable solution.

### 2.1 Intended use

The adsorber is exclusively designed for purifying compressed air!

Using the adsorber for treating other gases (e.g. pure nitrogen) must be agreed on with the manufacturer. It may be necessary to observe special safety directives.

The adsorber is designed to be set up at a site that complies with the following requirements:

- Indoors
- Protected against weather impact
- Frost-free
- Dry
- No vibration via floor or connected piping
- Free from dangers due to explosive atmospheres inside and outside the adsorber. (The standard adsorber version does not comply with ATEX.)

The adsorber must only be operated with compressed air within the maximum allowable operating conditions. The maximum allowable operating conditions are specified on the type plate (→page 12).

Modifications to the adsorber or use of third-party parts may cause unpredictable danger and damage. These measures must only be carried out after previous check and approval of the manufacturer. Only use genuine spare parts of the manufacturer.

Any other use is considered improper and therefore not permissible. The manufacturer accepts no liability caused by improper use.

The values specified on the type plate are mechanical design limits. Please note that adsorber performance is not defined to these mechanical design limits. Adsorber performance is guaranteed for use under the "nomi-

## Description of application

---

nal operating conditions" as well as for a certain combination of the individual operating parameters, that has been established for this adsorber in the planning phase (compressed air flow rate, pressure, temperature).

For the nominal operating conditions please refer to the following table. (→Page 11)

For a adsorber designed to your individual operating conditions, please refer to your contract documents or contact the manufacturer.

Adsorber performance cannot be guaranteed if the adsorber is not operated within these operating conditions.

The supplied compressed air must be of the following quality:

- Free from aggressive and corrosive substances
- Filtered \*
- Free from substances damaging the granulate

\*= Generally the adsorber can be operated with non-filtered air. However, the contaminants load on the adsorber becomes considerably higher and the life time of the granulate is considerably decreased.

We recommend using a coalescing fine filter upstream of the adsorber as pre-treatment at the least.

The purification performance of the adsorber is considerable decreased when operating the adsorber with moist or moisture saturated air. Therefore the compressed air should be dry or the moisture content should be notably sub-saturated.



### **Moisture reduces the purification performance of the adsorber**

Moisture in the compressed air reduces the lifetime and the purification performance of the granulate. Install the adsorber downstream of compressed air adsorber. The relative humidity of the compressed air shall not exceed 30% rH. For moisture saturated compressed air a reduction of adsorber performance of app. 50% has to be taken into account.

The ideal operating conditions for the adsorber are cold and dry.



### **High compressed air temperatures reduce the purification performance of the adsorber.**

The ability of the granulate to take up oil and other substances strongly depends on the temperature. The colder the compressed air, the better the purification performance and the longer the lifetime of the granulate. Furthermore a low temperature reduces the oil vapour content in the compressed air. Consequently the oil load on the adsorber is reduced the lifetime is considerable increased.

Temperatures below 35°C are ideal for operating the adsorber.

Note: even short temperature spikes above 60°C can lead to previously adsorbed oil being released from the granulate back into the compressed air flow.

Make sure that the compressed air temperature stays low and avoid heavy temperature changes.

## 2.2 Technical data

Adsorber	Nominal volume flow rate	Compressed air connection	Weight	Height	Width	Depth
	V [m <sup>3</sup> /h]*		[kg]	[mm]	[mm]	[mm]
<b>DSS 1</b>	8	G 3/8"	3	392	158	185
<b>DSS 2</b>	15	G 3/8"	5	567	158	185
<b>DSS 3</b>	25	G 3/8"	7,5	817	158	185
<b>DSS 4</b>	35	G 3/8"	10	1067	158	185
<b>DSS 6</b>	57	G 1/2"	20	1107	208	208
<b>DSS 7</b>	72	G 1/2"	24	1332	208	208
<b>DSS 8</b>	82	G 1/2"	28	1532	208	208

\* = Standardised to 1 bar(a) and 20°C as well as to the following operating conditions: 7 bar operating overpressure, 35°C inlet temperature and a relative humidity in the compressed air of less than 30%.

Classification acc. to PED 97/23/EG	DSS1...2: art.3 paragraph 3 DSS3...8: category I
Fluid group	2
Min. / max. allowable pressure (PS)	4 bis 16 bar
Min. / max. allowable temperature (TS)	+1 bis +50°C



### Individual operating conditions

Please contact the manufacturer when your operating conditions are not within the limits stated above.

Options adapting the adsorber to your operating conditions can be provided for numerous special cases.

## 3. Safety notes

The adsorber has been built according to state-of-the-art technology and recognised safety rules. However, there is a risk of danger that every person working with the adsorber must be aware of. In particular, improper handling of compressed air may result in serious injury or death. If you are not experienced in using these systems, please ask the relevant experts for help.



### Note!

- In order to prevent personal injury or damage, the safety notes must be observed when using this adsorber.
- Observe the specific safety notes in the relevant chapters.
- Observe the legal guidelines and the accident prevention regulations.
- Observe the safety notes of the local site regulations.

### 3.1 Signs and instructions

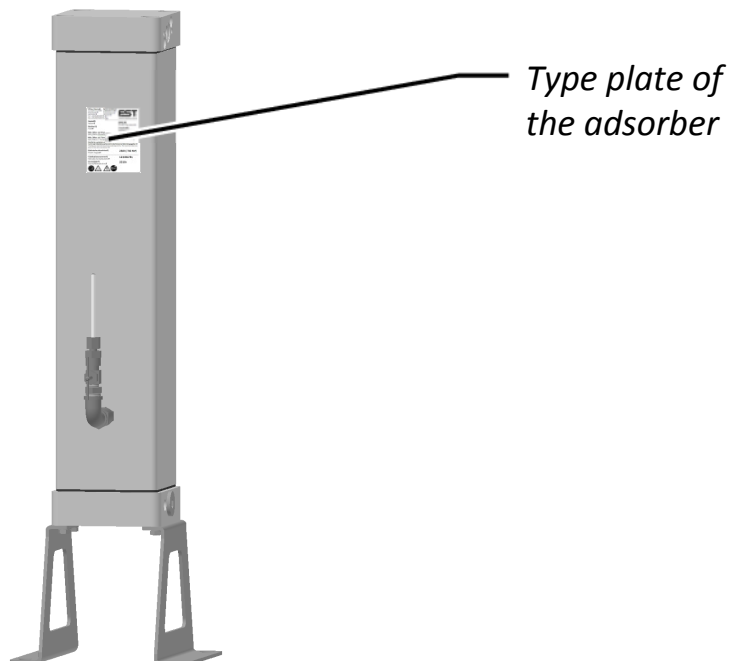

The type plates show important information. Make sure that the type plates are always clearly readable.

### 3.2 Danger zones at the adsorber

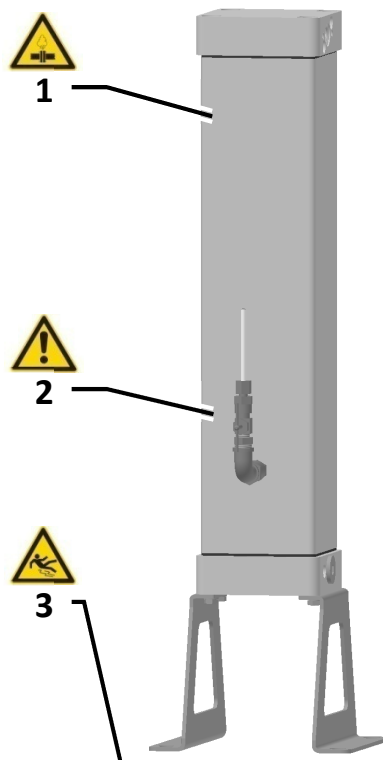

- 1** Risk of injury from pressure-bearing parts
- 2** Risk of injury from loose indicator tube
- 3** Risk of slipping due to spilt granulate



**DANGER ! – Overpressure (1)**

The adsorber is under pressure.

Suddenly escaping compressed air may result in serious injury.

Do not carry out mechanical work on the adsorber as long as the adsorber is under pressure.



**WARNING ! – Loose indicator tube (2)**

The indicator tube may break or loosen. When opening the valve at the indicator, the pressure may cause the indicator tube to be expelled.

This may lead to serious eye injury.



Check if the indicator tube is securely fixed by slightly pulling it by hand prior to opening the needle valve.

Open the valve carefully and turn away from the indicator.

Wear eye protection when working on the indicator.



**WARNING ! – Risk of slipping (3)**

After granulate replacement some amounts of granulate may still remain on the floor.

The granulate is very slippery and may result in serious fall injury.

Immediately remove residual granulate properly from the floor.

# Safety notes

---

## 3.3 General safety notes



### **DANGER ! – Overload**

The adsorber must only be operated with compressed air within the maximum allowable operating conditions. The operating conditions are defined on the type plate (→ Page 12).

Exceeding the maximum allowable operating conditions may result in serious injury or death.

It is the duty of the operator to ensure that the connected pressure source is safe-guarded such that the maximum allowable operating pressure (PS) and the maximum allowable temperature (TS) are not exceeded.

Please also refer to section "Intended use" (→ Page 9).



### **DANGER ! – Unauthorised modifications**

Modifications to the adsorber may result in dangerous operating states. Violations may cause serious injury or death.

Never modify the adsorber function by means of conversions.

Never carry out welding work on pressure-bearing parts.

Any modifications of the adsorber must be agreed on with the manufacturer and confirmed in writing.



### **DANGER ! – Suspected misuse**

Using the adsorber for unintended purposes may result in dangerous situations. Violations may cause serious injury or death.

Never use the adsorber as a climbing aid.

Never use the adsorber as a support for external weight loads.

Never use adsorber components for unintended application purposes.

Please also refer to section "Intended use" (→ Page 9).



### **WARNING ! – Risk of falls**

The adsorber must never be used as a climbing aid. The adsorber components will not provide adequate support and parts of the adsorber may break off. Disregard may lead to adsorber damages and falls with serious injuries.

When working at height only use approved climb assist systems.



### **CAUTION ! – Granulate dust**

Using the granulate may lead to mineral dust formation.

Granulate dust may cause eye and respiratory tract irritations.

Wear eye protection and a dust mask when handling the granulate.





**CAUTION ! – the granulate is combustible (activated charcoal)**

The granulate is combustible.

Avoid sparks and open fire in the vicinity of the granulate.

In case of fire there are no limitations regarding the extinguishing agent for unused granulate

The manufacturer recommends: CO<sub>2</sub>; extinguishing powder or water spray jet. For a bigger fire use water spray jet or alcohol resistant foam.

Please note that - depending on the contamination of the granulate - special fire extinguishing measures might be required.

---



**Granulate (activated charcoal)**

The granulate used is not subject to labelling requirements according to the Hazardous Substances Ordinance. Nevertheless, the common safety measures with regard to using chemicals apply.

The manufacturer will provide safety data sheets on request.

The granulate accumulates contaminants from the compressed air. Depending on the type of contamination there may be a risk of injury or damage when handling the granulate. As the type of contamination is not known to the manufacturer, the resulting risks cannot be evaluated in this operating manual.



**Additional safety notes**

For additional safety notes, please refer to the relevant chapters.

## 4. Technical product description

### 4.1 Assembly drawing

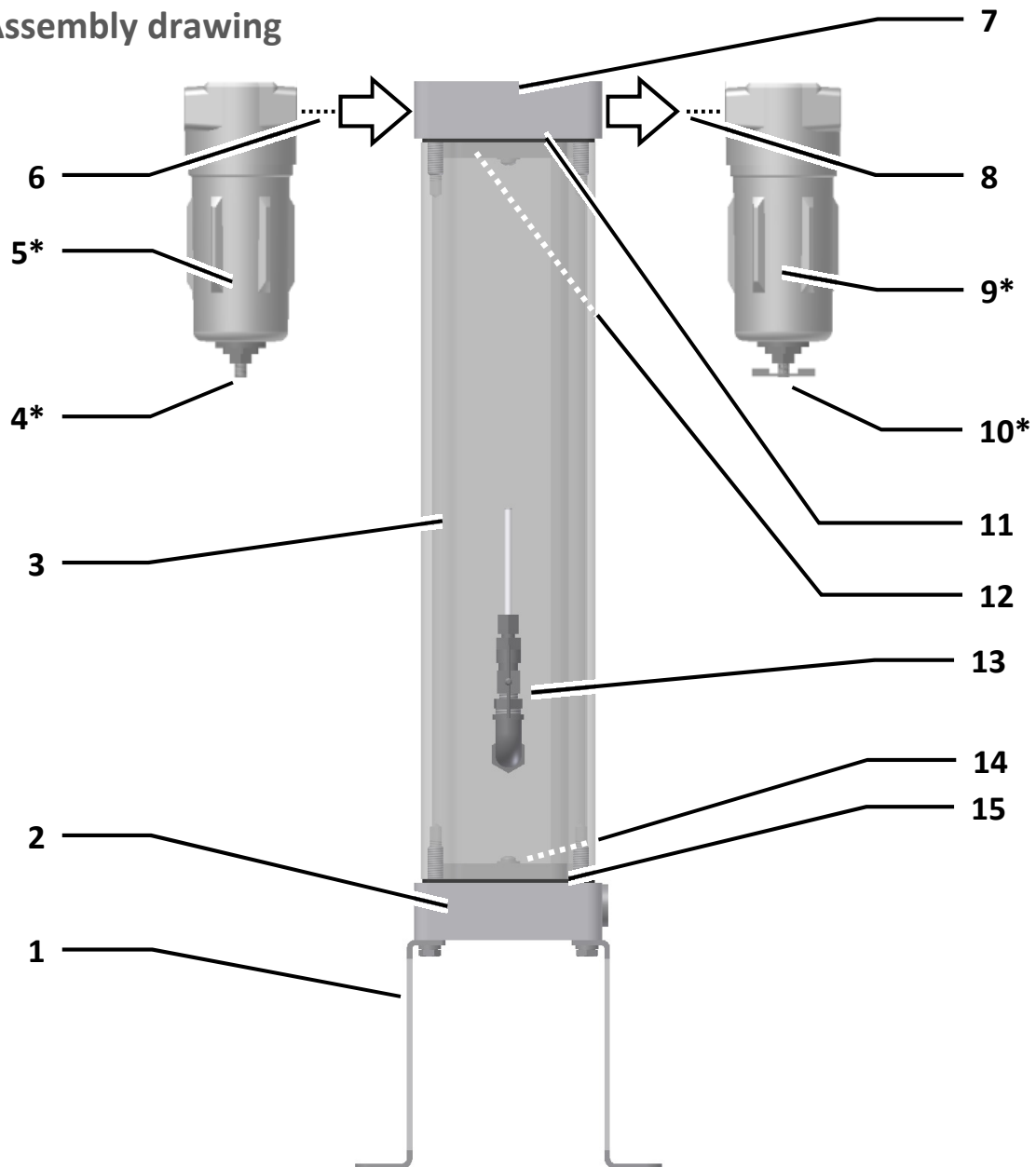

- |          |   |              |   |
|----------|---|--------------|---|
| <b>1</b> | <i>Adsorber supports</i>  | <b>7</b>     | <i>Upper vessel cover plate</i>   |
| <b>2</b> | <i>Lower vessel cover plate</i>   | <b>8</b>     | <i>Compressed air outlet (GO)</i>   |
| <b>3</b> | <i>Vessel (A3) with granulate filling</i>                               | <b>9</b>     | <i>After-filter (F2) (*optional)</i>  |
| <b>4</b> | <i>Condensate drain (D1) and<br/>Condensate outlet (CO) (*optional)</i> | <b>10</b>    | <i>Manual drain valve (HV1)(*optional)</i>                                    |
| <b>5</b> | <i>Pre-filter (F1) (*optional)</i>                                      | <b>11,15</b> | <i>gasket</i>   |
| <b>6</b> | <i>Compressed air inlet (GJ)</i>  | <b>12,14</b> | <i>Demister-Pad (SD2), inside</i>   |
|          |   | <b>13</b>    | <i>Oil indicator (QI), pressure reducer (PC) and<br/>shut off valve (HV1)</i> |



## 4.2 Process diagram

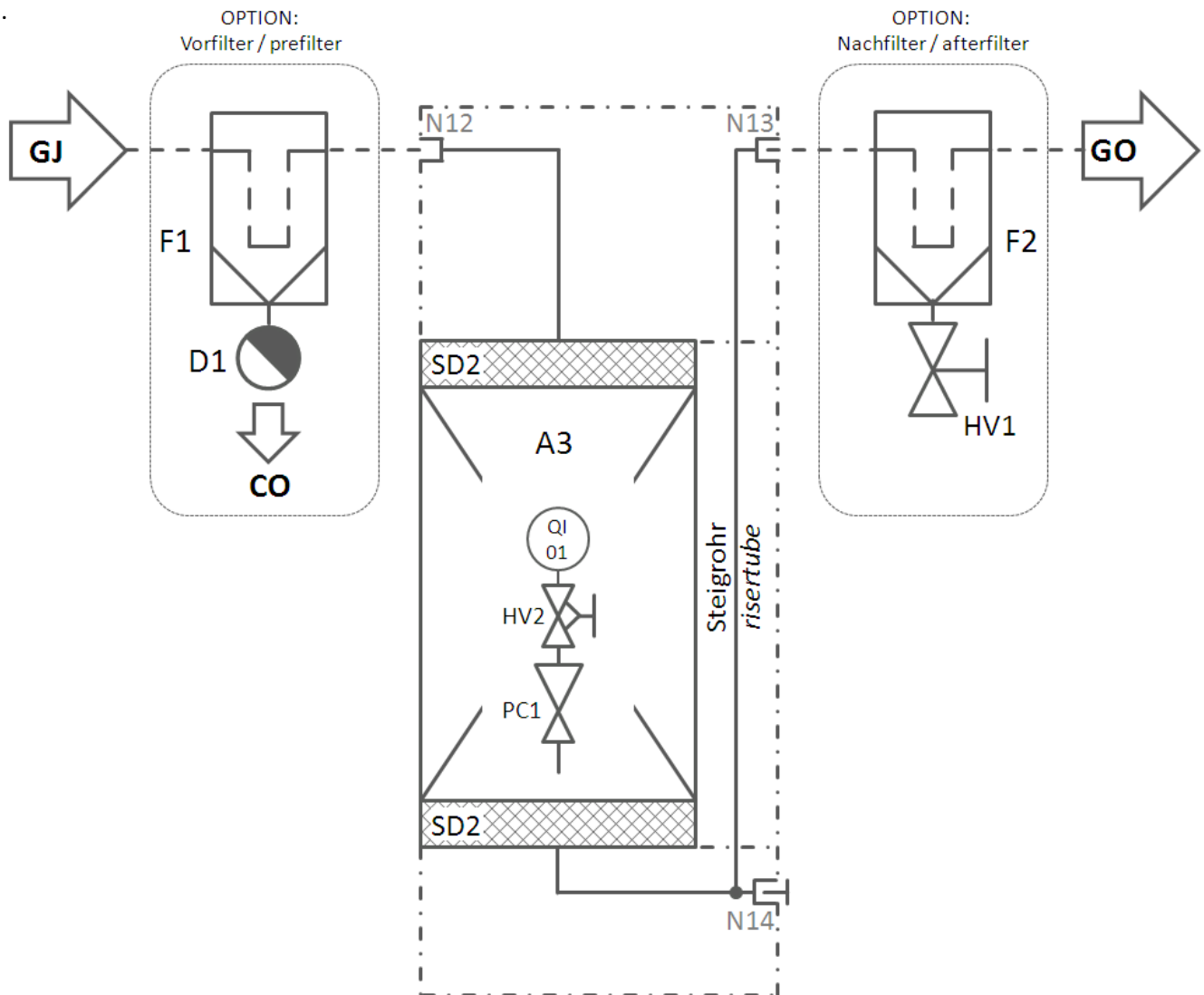

A	Vessel (A3) with granulate filling	QI	Öl-indicator with sample flow control
F	Filter	PC	Pressure reducer 7bar[ü]
HV	Manual shut off valve	GJ	Gas inlet (connection N12)
SD	Demister-Pad	GO	Gas inlet (connection N13)
D	Condensate drain	CO	Condensate outlet
		N14	Alternative connection for gas outlet

### 4.3 Function description

The operation principle of the adsorber is the purification of compressed air through adsorption. The principle of adsorption is molecules from oil vapour, smells or gustatory substances being attracted to a oleophilic solid material (activated charcoal).

The compressed air flow from a compressed air source (e.g. compressor) is led to the adsorber inlet (GJ). The compressed air flows through the strainer basket (S) into the vessel (A). The flow is distributed equally over the vessel cross-section. The compressed air is guided through a vessel containing the granulate and brought into intensive contact with the granulate.

The granulate removes oil vapour and other contaminants from the compressed air and stores it in its internal structure.

The purified compressed air leaves the vessel through the lower pipe elbow and proceeds to the adsorber outlet.

With continuous loading of the granulate with contaminants the adsorber performance is gradually reduced until the granulate is saturated with contaminants.

Now the saturated granulate has to be exchanged by fresh granulate.

The lifetime of the granulate filling depends on the quality of the raw compressed air. Under good compressed air conditions lifetimes of over 10.000 operating hours can be reached.

## 4.4 Options

Various options are available for improved operation and special installation site conditions. For detailed information on the options or adsorber modification to meet your operating and installation site requirements, please contact the manufacturer or the responsible sales partner

### Pre- and after-filter

The upper vessel cover plate is fitted with bolt holes that allow for the direct installation of pre- and after-filter.

Suitable filters:

DSS 1-4 : Filter type FCA 25

DSS 6-8 : Filter type FCA 50 or FCA 70

### Automatic start-up device (pressure maintaining valve)

The adsorber must always be operated with an adequately high pressure in order to avoid excessive flow velocities in the adsorber. There is a danger of damage to the adsorber. (→ Page 26)

If the adsorber is started against a pressureless compressed air network, the compressed air network must be filled through the adsorber. To ensure adequate operating pressure in the adsorber the manual valve behind the adsorber must be throttled and only be opened very slowly.

In the event the adsorber is frequently started against pressureless compressed air networks (e.g. after the weekend) or if there is no personnel available for the start-up procedure, an automatic start-up device is useful. It ensures that there is an adequately high pressure in the adsorber at any time during operation.

## 5. Operating elements

The following sections describe the adsorber components used for monitoring and operation of the adsorber.

### 5.1 Oil indicator

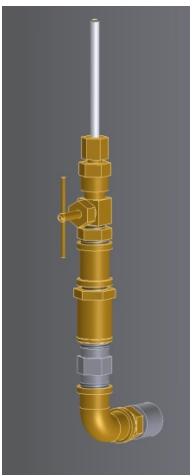

The oil indicator (QI) is used to periodically measure the residual oil content on the outlet side of the adsorber. The measurement can be performed by the operator in regular intervals.

You can find detailed operation instructions on → Page 31.

The location of the measuring point is in the lower third of the vessel cylinder. Thus the state of the upper granulate filling can be evaluated. The granulate filling below the measuring point serves as safety buffer.

The needle valve on the indicator is opened for the measurement, only. During the rest of the operation time the needle valve stays closed

## 6. Transportation, setting up and storage

### 6.1 Transportation

**DANGER ! – Damage**

Damages of the adsorber may lead to unpredictable hazardous situations.  
Operating a damaged adsorber may result in serious injury or death.  
Never start to operate a damaged adsorber.

**DANGER ! – Risk of tilting**

The centre of gravity is in the upper part of the adsorber.  
Tilting of the adsorber may result in serious injury.  
During transport and during loading and unloading secure the adsorber against tilting using the lifting lugs.

Although great care is taken damages caused by transportation cannot be ruled out. Therefore, always check the adsorber for possible damages after transportation and packaging removal.

The haulage contractor and the manufacturer or the sales partner must immediately be informed about any damage.

- Make sure to provide adequate lifting equipment when transporting and loading or unloading the adsorber.
- Persons responsible for transportation must be appropriately qualified.
- The adsorber must only be lifted at the appropriate points using lifting equipment. (Transport pallet; base frame; support feet)
- Take the adsorber weight and the maximum allowable load of the lifting and transport equipment used into account.
- Do not remove the packaging material until the adsorber is moved to its final place of installation.
- The national regulations for accident prevention must be adhered to.

## 6.2 Setting up

Please refer to section "Description of application" (→ page 9). Here, you will find a list of requirements on the installation site.

Important data of the adsorber can be found in section "Technical data" (→ Page 11).

Additional requirements on the installation site:

- The ground for adsorber installation must be level and capable to carry heavy loads. Ground irregularities must be levelled in order for tensional forces not to occur in the piping of the adsorber. Because of noise emissions the installation site should not be in the vicinity of stationary workplaces.
- Keep a service distance to walls and other systems around the adsorber of 1 m, minimum.
- During maintenance of the adsorber components lifting equipment with adequate load capacity should be available and access of this equipment to the adsorber must be ensured.
- The place of installation should not be in the vicinity of hallways in order to avoid risks to inexperienced persons.

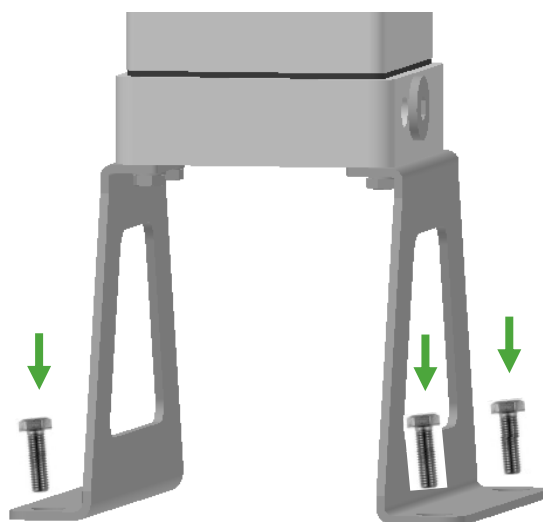

### 6.3 Storage

To maintain the adsorber quality the adsorber must be stored at a suitable location and properly prepared for storage.

The place of storage has to fulfil the following requirements:

- Indoors
- Protected against weather impact
- Frost-free
- Dry

If the adsorber is to be stored immediately after delivery, it must only be protected against dust using an additional cover.

If the adsorber has already been used for purification of compressed air, please proceed as follows:

- 1) Disconnect the compressed air flow from the adsorber by closing the valves up- and downstream of the adsorber.
- 2) Decommission the adsorber. (→ Page 28)
- 3) Depressurise the adsorber. (→ Page 28)
- 4) Disconnect the adsorber from the compressed air system.
- 5) Close the inlets and outlets of the adsorber using flange covers.
- 6) Protect the adsorber against dust using a cover.

To recommission the adsorber after storage, please proceed as described for initial commissioning. (→ Page 25)

## 7. Installation

### 7.1 Installing the connecting pipelines



**DANGER ! – Overpressure**

The adsorber is under pressure.

Suddenly escaping compressed air may result in serious injury.

Do not carry out mechanical work on the adsorber as long as the adsorber is under pressure.



**DANGER ! – Overload**

The adsorber must only be operated with compressed air within the maximum allowable operating conditions. The operating conditions are defined on the type plate (→ Page 12).

Exceeding the maximum allowable operating conditions may result in serious injury or death.

It is the duty of the operator to ensure that the connected pressure source is safe-guarded such that the maximum allowable operating pressure (PS) and the maximum allowable temperature (TS) are not exceeded.

Please also refer to section “Intended use” (→ Page 9).



**DANGER ! – Bursting components due to external forces**

The adsorber components are not designed for externally applied forces and may burst due to additional load impact.

Bursting, pressure-bearing components may result in serious injury or death.

The support required for the connected pipelines has to be provided by the customer. Transmission of loads or stress into the connection flanges of the adsorber is not permissible.

Proper installation is required for safe and error-free operation of the adsorber.

Please observe the following steps when installing the compressed air pipeline (4) + (6):

- Make sure that the adsorber and the compressed air system are free from pressure. If the compressed air system has to remain under pressure during installation, the shut-off valves have to be protected against unintentional opening. (2) + (8)
- The compressed air source (e.g. compressor) must be safe-guarded against exceeding of the maximum allowable operating pressure using safety equipment.
- The compressed air pipelines must be provided with shut-off valves used for disconnecting the adsorber from the piping system (2) + (8). We recommend using shut-off valves with continuous opening behaviour (e.g. shut-off valves with stem or gear handwheel). This valve behaviour avoids sudden pressure equalisation between the piping sections.
- We recommend using a bypass line (11) around the adsorber.
- The pipelines must be suitable for use with the maximum possible operating pressure.
- The transfer points (threaded or flanged connections) have to be compatible to the adsorber inlet and outlet with regard to nominal width, nominal pressure and type. (→ See general arrangement drawing in the appendix)
- Any vibrations or pulsation must not be transmitted to the adsorber via the piping. This may damage the granulate or other components. If required, install compensators or pulsation absorbers in the pipelines to be connected.

# Installation

- Wet pipelines upstream of the adsorber (4) should be installed at a slope in order for condensate (water and oil) in the line to be discharged in flow direction. If installation of an upright pipeline is inevitable, a condensate drain must be provided at the lowest point of the pipeline. This avoids condensate from being accumulated in the pipeline and suddenly being swept away by the compressed air flow. These kinds of water shocks may damage the filter and adsorber and must be avoided.
- Prior to closing the connected pipelines, please check that there are no objects or contaminations left in the pipelines.
- Remove the end caps from the adsorber inlet and outlet.
- When checking the installation for leaks the maximum allowable operating pressure of the adsorber must not be exceeded. (→ See specification on the type plate, page 12)

Never fill the adsorber with water when performing a pressure test. Liquids will destroy the granulate!

## Installation example

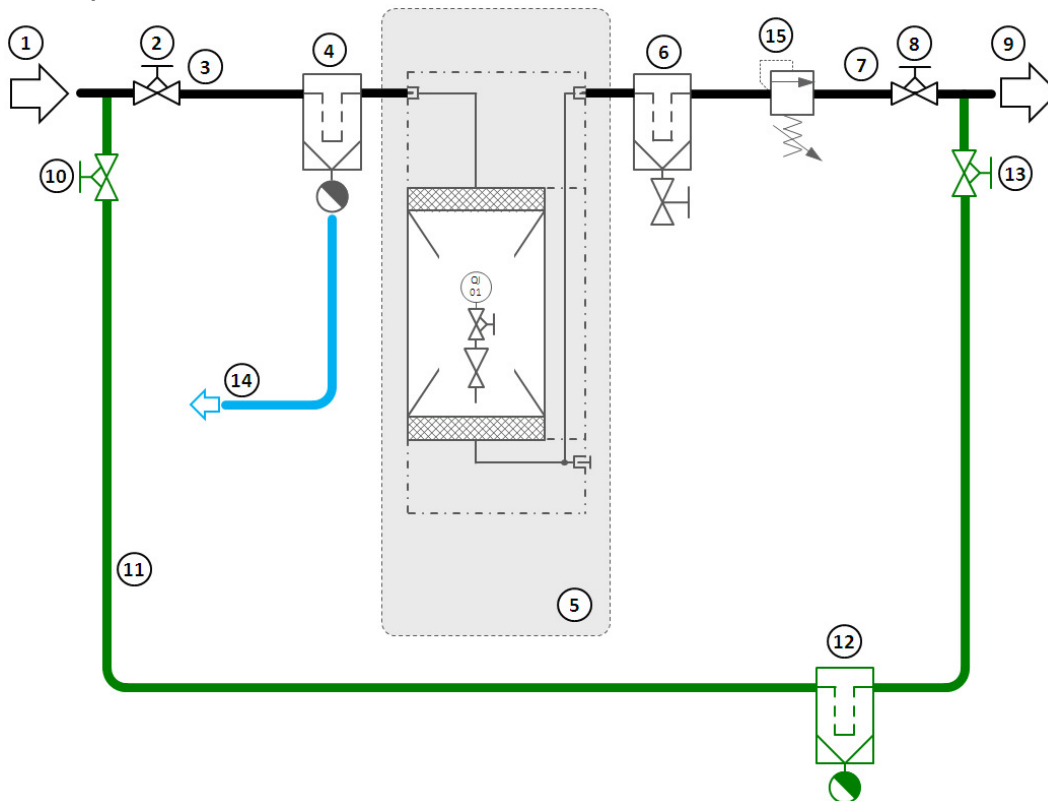

- |                                     |  |
|-------------------------------------|--|
| 1 Compressed air inlet              | 9 Compressed air outlet                |
| 2 Valve at compressed air inlet     | 10 Bypass valve at inlet               |
| 3 Compressed air pipeline at inlet  | 11 Bypass line                         |
| 4 Pre-filter with condensate drain  | 12 Bypass filter with condensate drain |
| 5 Adsorber                          | 13 Bypass valve at outlet              |
| 6 after-filter with manual drain    | 14 Condensate line                     |
| 7 Compressed air pipeline at outlet | 15 D Pressure maintaining valve        |
| 8 Valve at compressed air outlet    |  |

Please note that the standard scope of supply only comprises the adsorber (5). Position (4), (6), (12) and (15) can be purchased optionally. All other parts have to be provided on site



## 8. Commissioning



### **CAUTION ! – Qualification and experience required**

Persons working on and with the adsorber have to be qualified personnel who, because of their qualification and experience, are familiar with handling compressed air systems. If you are not experienced in using these systems, please ask the relevant experts for help. We highly recommend that commissioning and maintenance be carried out by the manufacturer or one of the authorised service partners.

### 8.1 Requirements for initial commissioning

All the requirements for unhindered commissioning must be fulfilled, especially when commissioning is carried out by external qualified personal.

Make sure the following requirements for initial commissioning have been fulfilled:

- External qualified personnel have been informed about the commissioning date in good time (2 weeks in advance, minimum).
- External qualified personnel have been informed about the following in good time: special local conditions; site-specific safety guidelines; required safety instructions, if necessary; specially required qualifications, if necessary; special personal protective equipment.
- The place of installation can be freely accessed and entered without any risks.
- Neighbouring construction sites do not affect commissioning.
- The adsorber is connected to the compressed air system using pipelines. (→ Page 23)
- The compressor is ready to operate and personnel for starting and operating the compressor are present.
- Compressed air can be delivered to the downstream system. A volume flow rate of at least 40% of the nominal adsorber performance can be led through the adsorber.
- The adsorber is classified pressure equipment (see declaration of conformity in the appendix). Prior to commissioning the adsorber has to be approved by the local authorities according to the applicable national regulations. In the EU, the Pressure Equipment Directive 97/23/EC has to be observed.

Please check the following directly before commissioning:

- The operating limits must not be exceeded. (→ Page 11)
- The shut-off valves provided by the customer and located upstream and downstream of the adsorber are closed.
- The connections may have become loose due to adsorber transportation. Make sure the piping connections, screwed joints and pneumatic lines are tightly secured. Tighten loose connections using the appropriate tools.
- Check all the components for visible damages. If there are defective components, commissioning of the adsorber is not permitted!

## 8.2 Commissioning the adsorber

---



### **DANGER ! – Overpressure**

The adsorber is under pressure.

Suddenly escaping compressed air may result in serious injury.

Do not carry out mechanical work on the adsorber as long as the adsorber is under pressure.

---



### **WARNING ! – Loose indicator tube**

The indicator tube may break or loosen. When opening the valve at the indicator, the pressure may cause the indicator tube to be expelled.

This may lead to serious eye injury.

Check if the indicator tube is securely fixed by slightly pulling it by hand prior to opening the needle valve.

Open the valve carefully and turn away from the indicator.

Wear eye protection when working on the indicator.

---



If all conditions required for commissioning are fulfilled, the commissioning procedure can be started. Perform the following steps in the listed order.

### 8.2.1 Pressurisation of the adsorber

---



### **CAUTION ! – Pressure blows and overload**

Rapid opening of the valves may cause pressure blows and increased flow rates in the adsorber. Pressure blows and increased flow rates may lead to damages of the adsorber.

Open the valves **very slowly** and make sure that the flow noise does not become too loud. Pay special attention when opening valves that can be opened rapidly by means of a pivoting movement.

---



Pressurise the adsorber as follows:

- 1) Make sure the compressed air system upstream of the adsorber inlet is under pressure. If necessary, the compressor must be started.
- 2) Open the valve upstream of the adsorber inlet **very slowly** until hearing the first clear flow noise. Stop the procedure when the flow noise becomes loud.
- 3) Check the system for leaks during pressurisation. In the event of leaks, pressurisation must be stopped and the leaks must be repaired. To repair the leaks the adsorber has to be depressurised again. (→ Page 28)
- 4) If flow noise and a pressure increase is no longer present when further opening the valve, it can be opened completely.

## 8.2.2 Opening the outlet valve

Special attention must be paid if the compressed air system downstream of the adsorber is free from pressure.

- 1) Open the valve downstream of the adsorber outlet **very slowly** until hearing the first clear flow noise.
- 2) If flow noise is no longer present when further opening the valve, it can be opened completely.
- 3) Now the adsorber is ready to operate.



### **Automatic start-up device**

In the event the adsorber is frequently started against a pressureless compressed air system, we recommend using an automatic start-up device. (→ Page 19)

The automatic start-up device prevents pressure blows and increased flow speeds from occurring even when the compressor is started automatically.

## 9. Shutting down and restarting the adsorber

### 9.1 Shutting down the adsorber

- 1) Close the valves upstream and downstream of the adsorber.
- 1) The adsorber has now been shut down.
- 2) Prior to working on the adsorber it has to be depressurised.

### 9.2 Depressurising the adsorber



#### **WARNING ! – Exhausting pressure**

Compressed air exhausting to the outside is very loud and may carry small particles.

This may cause hearing damage as well as injuries of the eyes and of the skin.

Close the openings used for releasing the pressure by means of a silencer suitable for the pressure.

Open the valves for releasing the pressure only **very slowly**.

Always wear eye and hearing protectors when working in the vicinity of the adsorber.



- 1) Close the valves upstream and downstream of the adsorber.
- 2) Open the valve on the after-filter (→ Page 16)
- 3) Monitor the pressure on the pressure gauges of the adsorber.
- 4) Wait until the pressure has dropped to 0 bar on both pressure gauges.

### 9.3 Restarting the adsorber

Please proceed as described in chapter "Commissioning". (→ Page 25)

If the relevant requirements have already been fulfilled, the corresponding steps of the chapter can be skipped.

## 10. Maintenance and repair



### **DANGER ! – Overpressure**

The adsorber is under pressure.

Suddenly escaping compressed air may result in serious injury.

Do not carry out mechanical work on the adsorber as long as the adsorber is under pressure.



### **CAUTION ! – Qualification and experience required**

Persons working on and with the adsorber have to be qualified personnel who, because of their qualification and experience, are familiar with handling compressed air systems. If you are not experienced in using these systems, please ask the relevant experts for help. We highly recommend that commissioning and maintenance be carried out by the manufacturer or one of the authorised service partners.

Please observe the following requirements for maintenance:

- Observe the notes in section "Intended use". (→ Page 9)
- Observe the "Safety notes" and the "General safety notes" in particular. (→ Pages 12,14)
- Provide the required spare parts. Only use genuine spare parts of the manufacturer. The manufacture provides prepared spare part packets.
- Maintenance must only be carried out if the adsorber is depressurised. (→ Page 28)

Please observe the following when completing maintenance work:

- Make sure that all the flange connections and screwed joints are tight and sealed.
- Carry out a leak test.
- Make sure not to forget any tools, detergents or other objects in and around the adsorber.
- Commission the adsorber as described on → Page 25.



### **Maintenance contract**

It is possible to conclude a maintenance contract with the manufacturer or one of their service partners. A maintenance contract guarantees that the adsorber has been maintained regularly by qualified personnel and that only genuine spare parts are being used.

For contact data, please refer to → Page 5.

For communication purposes, please specify the type and the manufacturing number. This information can be found on the vessel of the adsorber. (→ Page 12)

## 10.1 Regular maintenance intervals

The following table gives an overview of routine maintenance tasks. The required activities are described on the following pages.

Component	Maintenance activity	Every day	Every month	Every year	See page
Adsorber and pre- and after-filter (Option)	Visual check and function monitoring	■			30
Adsorber and pre- and after-filter (Option)	Clean		■		30
Oil indicator	Determine residual oil content in the compressed air		■		31
Oil indicator	Exchange indicator tube		(■)	(■)	32
Demister (SD2)	Clean			■ *	33
Granulate	Check/replace		(■ *)	■ *	33

\* = These activities should be carried out at the same time.

### 10.1.1 Visual check and function monitoring

- 1) Check the adsorber for external damages.
- 2) Check the operating parameters of the incoming compressed air (pressure and temperature in particular). (→ Page 11)
- 3) Check the individual components for unusual noise development and leaks.
- 4) Look out for noticeable problems and possible disturbance of the overall process.
- 5) Check if the condensate drains on the compressor and on the upstream filters are working properly.
- 6) Check the after filter for separated oil and condensate. To check please open the hand valve on the after-filter. There should be no oil traces in the after-filter when the adsorber works properly.

### 10.1.2 Cleaning the adsorber

Make sure the surroundings are clean and tidy.

- 1) Clean the adsorber surface using a slightly moist cloth. Do not use detergents containing acids or solvents.
- 2) Make sure the operating elements and the type plates can always be clearly read.
- 7) Prüfen Sie die Kondensatableiter am Kompressor und Vorfilter auf Funktion.

### 10.1.3 Determining the residual oil content in the compressed air

The oil indicator (QI) is used to periodically measure the residual oil content on the outlet side of the adsorber. The measurement can be performed by the operator in regular intervals.

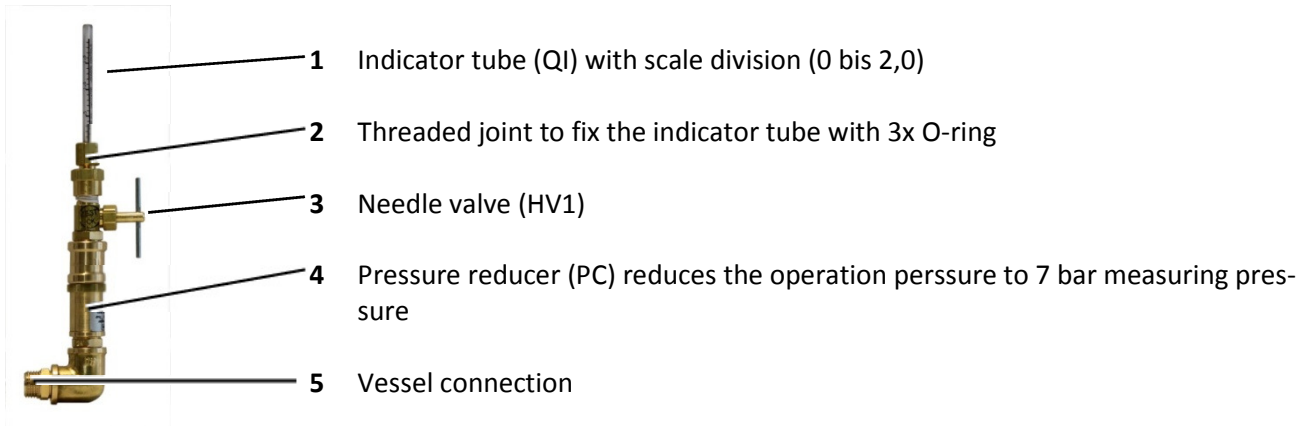

The measuring principle is as follows: For the duration of the measurement, the needle valve (3) is opened so that a pressure-reduced partial flow of purified compressed air is fed through the indicator tube (1). The indicator tube is secured by means of a union nut (2).

Any residual oil contained in the air leads to a change of colour of the scale segments of the tube, whereby a higher concentration leads to more segments being coloured.

The change of colour is irreversible; after completion of the measurement, the indicator tube must thus be replaced

To measure the residual oil concentration, proceed as described below. A template of the measuring log used for this procedure is included in the appendix.



#### **WARNING ! – Risk of loose indicator tube**

Risk of damage to eyes! If not properly secured, the indicator tube might be propelled out of its holder.



Prior to opening the needle valve, check that the union nut at the indicator tube is properly tightened.

When working at the oil indicator, always wear protective goggles.

- 1) Prepare measuring log and hold it ready.
- 2) Check union nut holding the indicator tube and retighten, if necessary.
- 3) At the indicator tube, mark the highest segment with a colour change, using a suitable pen.
- 4) Open needle valve by turning its handle anticlockwise. Write down start date and time of the measurement..
- 5) Leave needle valve open for the desired duration of measurement (e.g. 5 hours)..
- 6) Subsequently, close the needle valve. Write down end time of measurement.
- 7) At the indicator tube, mark the highest segment with a colour change, using a suitable pen. Write down the number of scale segments that have changed colour since the start of the measurement.
- 8) Determine the concentration in the above table, based on the duration of the measurement and the number of scale segments with colour
- 9) Write down the residual oil concentration in ppm, parts per million] in the measuring log.
- 10) To determine the residual oil content in  $[\text{mg}/\text{m}^3]$ , multiply the above value by a factor 1.2. Write down this value in the measuring log.

# Maintenance and repair

---

**Example:** Duration of measurement = 25 h  
No. of scale segment with colour change = 0,3 (= approx 7mm)  
Operating pressure during measurement = 8,5 bar (ü)

It follows ... ⇒ table 1. is to use !  
admissible residual oil concentration  
for 0,2 scale change ⇒ 0,09 ppm  
for 0,4 scale change ⇒ 0,18 ppm  
for 0,3 scale change ⇒  $(0,09 + 0,18)/2 = 0,135$  ppm  
residual oil content in  $\text{g/m}^3$  ⇒ **0,135 x 1,2 = 0,162  $\text{mg/m}^3$**

- 1) Choose a measuring interval (e.g. 4 weeks) and a duration of measurement (e.g. 4 hours)
- 2) To establish the remaining capacity of the purifying agent, you must carry out measurements of the same duration at fixed intervals
- 3) Record the development of residual oil content over the time.
- 4) If the residual oil begins to rise more rapidly, the granulate is exhausted and must be replaced.

## 10.1.4 Replacing indicator tube

If all scale segments in the indicator tube show a colour change, the indicator tube is spent and must be replaced.



### **WARNING ! – Risk of loose indicator tube**

Risk of damage to eyes! If not properly secured, the indicator tube might be propelled out of its holder.



Prior to opening the needle valve, check that the union nut at the indicator tube is properly tightened.

When working at the oil indicator, always wear protective goggles.

- 1) Ensure that the needle valve (3) is closed and that the indicator tube (2) is not under pressure. To close the needle valve, turn its handle clockwise.
- 2) Loosen the reducer (2) below the union nut, using an appropriate tool. Fix locknut with a second roller wrench so that the needle valve (3) is not turning.
- 3) Exchanging the old indicator tubes against a new indicator tube. Pull the three O-rings on the new indicator tube, so that stands out approx. 10 mm of lower pipe end from the O-rings
- 4) Check the union nut and the reducer below (2) to ensure that they are properly tightened, and new indicator tube is properly fixed.
- 5) Open the needle valve (3) for a short time and check screw connections for tightness.



### 10.1.5 Checking and replacing the granulate / Cleaning the strainer basket

**WARNING ! – Risk of slipping**

After granulate replacement some amounts of granulate may still remain on the floor.  
The granulate is very slippery and may result in serious fall injury.  
Immediately remove residual granulate properly from the floor.

**CAUTION ! – Granulate dust**

Using the granulate may lead to mineral dust formation.  
Granulate dust may cause eye and respiratory tract irritations.  
Wear eye protection and a dust mask when handling the granulate.

**CAUTION ! – the granulate is combustible (activated charcoal)**

The granulate is combustible.  
Avoid sparks and open fire in the vicinity of the granulate.  
In case of fire there are no limitations regarding the extinguishing agent for unused granulate  
The manufacturer recommends: CO<sub>2</sub>; extinguishing powder or water spray jet. For a bigger fire use water spray jet or alcohol resistant foam.  
Please note that - depending on the contamination of the granulate - special fire extinguishing measures might be required.

The granulate is gradually laden with contaminants and its purification performance is reduced over time. The service life of the granulate depends on numerous operating parameters and cannot be exactly predicted. The service life under favourable conditions is approximately 10.000 operating hours. Under very favourable conditions (e.g. oil-free compressed air) the service life may be considerably longer.

The quality of the granulate can be assessed by regular measurements with the oil indicator. A granulate exchange is recommended in annual intervals as a preventive maintenance measure.

Granulate replacement is generally useful as a preventive maintenance measure in conjunction with other repair work. (See advisory note below)

**WARNING ! – Risk of slipping**

After granulate replacement some amounts of granulate may still remain on the floor.  
The granulate is very slippery and may result in serious fall injury.  
Immediately remove residual granulate properly from the floor.

Granulate replacement is part of a large inspection run. At the same time, other maintenance activities should be carried out. (See maintenance table → page 30)

- 1) Decommission the adsorber. (→ Page 28)
- 2) Depressurise the adsorber. (→ Page 28)
- 3) Untighten the screws on the upper vessel cover plate and remove the plate.
- 4) Remove the demiste pad (SD2).
- 5) Remove the gasket.

## Maintenance and repair

---

- 6)
- 7) Provide adequate support for the pipelines connected to the adsorber and make sure the connection points are not subject to stress.
- 8) Remove the pipe elbows above the vessels.
- 9) Remove the strainer basket (S) and clean it from granulate residues.
- 10) Remove the seals and clean the flange surfaces from residues of the seals.
- 11) Provide a suitable containment for the used granulate.
- 12) Remove the used granulate from the vessel using a suction device. E.g. vacuum cleaner.
- 13) Remove the used granulate from site.
- 14) Fill in the new granulate. Be aware of granulate dust and wear a dust mask.
- 15) Fill up the vessel almost to its full extent. Make sure that there is still some space available for the demister pad (SD2) to be inserted.
- 16) Install a new demister pad (SD2)
- 17) Install the upper vessel cover plate using a new gasket.
- 18) First tighten the screws only lightly. Then tighten completely in a crosswise manner.
- 19) Clean the bottom thoroughly from desiccant residues.
- 20) Slowly pressurise the adsorber again. (→ Page 26) Carry out a leak test using a leak detection spray. In the event of leaks the adsorber will have to be depressurised prior to repairing the leaks.

Please note that, the new granulate might contain moisture. Compressed air, that had been dried by an adsorption adsorber, will be humidified by the new granulate. It might take a couple of days until the granulate is dried-out and no more moisture is released into the compressed air flow.



### **Increased dust contents after granulate replacement**

Filling the new granulate in the adsorber results in increased dust contents in the vessels. In the first weeks after recommissioning the dust is forwarded to the downstream filter and the filter elements will deteriorate faster than during later operation. We therefore recommend to recommission the adsorber using the old filter elements and to use the new filter elements and the new expansion silencer only after some weeks.



### **Granulate (activated charcoal)**

The granulate used is not subject to labelling requirements according to the Hazardous Substances Ordinance. Nevertheless, the common safety measures with regard to using chemicals apply.

The manufacturer will provide safety data sheets on request.

The granulate accumulates contaminants from the compressed air. Depending on the type of contamination there may be a risk of injury or damage when handling the granulate. As the type of contamination is not known to the manufacturer, the resulting risks cannot be evaluated in this operating manual.



### **Disposal**

Dispose of the granulate according to the local regulations.

#### **Waste codes according to the Waste Catalogue Ordinance:**

- Non-contaminated granulate: „used activated charcoal“ 06 13 02
- Contaminated granulate: The waste code will have to be determined by the waste producer taking the type of contamination into consideration. The granulate must be disposed of in an appropriate disposal plant.

### **10.1.6 Replacing filter elements (Option)**

The filter elements in the filters prevent particles and aerosols in the compressed air flow from entering the system. The filter elements in the filters will be clogged over time and thus the compressed air flow is throttled. To prevent operating errors from occurring, the filter elements have to be replaced regularly. Check the differential pressure gauge at the filter (if available). When exceeding approximately 350 mbar, the elements should be replaced. Replacement is due after one year at the latest.

- 1) Depressurise the filter. (→Page 28)
- 2) For filter replacement please proceed as described in the operating manual of the filter.

## 11. Faults and measures



### CAUTION ! – Qualification and experience required

Persons working on and with the adsorber have to be qualified personnel who, because of their qualification and experience, are familiar with handling compressed air systems. If you are not experienced in using these systems, please ask the relevant experts for help. We highly recommend that commissioning and maintenance be carried out by the manufacturer or one of the authorised service partners.

The following table indicates the possible reasons of the fault and states the recommended measures to remedy the faults.

Fault	Reason / Event	Recommended measures
Oil in the pipeline downstream of the adsorber	<ul style="list-style-type: none"> <li>■ volume flow too high</li> <li>■ Operation pressure too low</li> <li>■ Inlet temperature too high</li> <li>■ Strong variation of inlet temperature</li> <li>■ Faulty pre-filtration</li> <li>■ Faulty condensate drain on pre-filter</li> <li>■ Bypass valve is open</li> <li>■ The downstream piping had already been contaminated with oil during installation</li> <li>■ The Bypass valve had been open before the commissioning of the adsorber</li> <li>■ Oil break through on the compressor</li> <li>■ Granulate is used up.</li> </ul>	<ul style="list-style-type: none"> <li>■ Check compressed air entry conditions and correct the entry conditions to the specified values. (→ Page 11)</li> <li>■ Use additional cooling of the compressed air, if required.</li> <li>■ Check pre-filter and exchange the filter element, if required.</li> <li>■ Check the function of the condensate drain and correct defects.</li> <li>■ Keep bypass valve closed and secure against unintentional opening.</li> <li>■ Clean or exchange the piping.</li> <li>■ Monitor and continuously take notes of the oil consumption on the compressor and correct defects, if required.</li> <li>■ Exchange the granulate.</li> </ul>
High pressure loss over the adsorber	<ul style="list-style-type: none"> <li>■ Shut off valves are closed</li> <li>■ High differential pressure on pre- and after-filter.</li> <li>■ high dust load and encrustation are choking the flow through the piping</li> <li>■ high turbulence in the vessel cause abrasion of the granulate in the upper granulate layers and formation of dust</li> </ul>	<ul style="list-style-type: none"> <li>■ Check and open valves.</li> <li>■ Check pre-filter and exchange the filter element, if required.</li> <li>■ Large amounts of granulate dust, that are repeatedly found in the after-filter, can be evidence of high flow turbulence in the vessel inlet and formation of dust through abrasion. The granulate is fluidised by the incoming, turbulent compressed air jet and is gradually crushed by the movement. Pay attention to the correct positioning of inlet and outlet. Avoid high compressed air velocities in the adsorber. (→ Page 19)</li> <li>■ Check the condition of the granulate. Open the vessel connections and remove encrustations. Shut down the adsorber before opening the vessel. (→ Page 28)</li> </ul>



### **Monitor the compressor performance**

The main source of oil in compressed air are oil lubricated compressors.

Insufficiently cooled and poorly maintained compressors lead to excessively high oil entrainment to the downstream adsorber.

Regularly check the oil consumption and monitor the changes in oil consumption over longer time intervals. Perform regular maintenance on the compressor.



### **VORSICHT ! – Qualifikation und Erfahrung erforderlich**

Personen, die Arbeiten an und mit dem Adsorber durchführen, müssen Fachpersonal sein und aufgrund ihrer Qualifikation und Erfahrung im Umgang mit Druckluftanlagen geübt sein. Wenn Sie keine Erfahrung mit solchen Anlagen haben, sollten Sie fachkundige Hilfe in Anspruch nehmen.

Wir empfehlen dringend die Inbetriebnahme und Wartungen durch den Hersteller oder einen seiner autorisierten Vertragspartner durchführen zu lassen.

Die nachfolgende Tabelle erklärt mögliche Ursachen von Störungen und nennt empfohlene Maßnahmen zur Behebung

### 12. Appendix and technical documents

#### 12.1 Manufacturer's declaration

## Manufacturer's Declaration

Herewith we declare that the below mentioned products in their conception and design in which we placed them on the market comply with the standards and directives mentioned below.

<b>Manufacturer/authorised representative:</b>	FST GmbH Weiherdamm 17 57250 Netphen, Germany
<b>Description of the assembly:</b>	Adsorber Type DSS1 to DSS2
<b>Description of the pressure equipment constituting the assembly:</b>	The dryer is described in the operating manual in detail.
<b>Harmonised standards applied:</b>	DIN EN ISO 12100
<b>Other European Commission directives applied:</b>	97/23/EC annex I

In case changes are made to the product without prior consultation and written approval of the manufacturer this declaration will become void.

Signature:

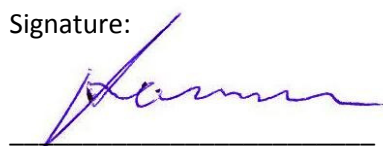

02.02.2016, Norbert Hannen, General manager

## 12.2 Declaration of conformity

# EC – Declaration of Conformity

## acc. to the pressure equipment directive 97/23/EG

Herewith we declare that the below mentioned products in their conception and design in which we placed them on the market have undergone the procedures of conformity assessment acc. to annex III of the above mentioned directive and are in conformity with this directive.

<b>Manufacturer/authorised representative:</b>	FST GmbH Weiherdamm 17 57250 Netphen, Germany
<b>Description of the assembly:</b>	Adsorber Type DSS3 to DSS8
<b>Description of the pressure equipment constituting the assembly:</b>	The dryer is described in the operating manual in detail.
<b>Conformity assessment procedure followed:</b>	Module A
<b>Harmonised standards applied:</b>	DIN EN ISO 12100
<b>Other Community Directives applied:</b>	97/23/EC annex I

In case changes are made to the product without prior consultation and written approval by the manufacturer this declaration will become void.

Signature:

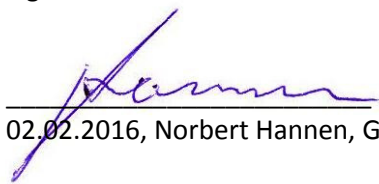

02.02.2016, Norbert Hannen, General manager

## 12.3 Tables for oil indicator

### 12.3.1 $\geq 7$ bar (g)

Residual oil content in ppm (parts per million) at an operating pressure of 7 bar(g) and higher:

Scale [h] Duration	0,2	0,4	0,6	0,8	1,0	1,2	1,4	1,6
4,2	0,548	1,096	1,644	2,192	2,740	3,288	3,836	4,384
4,5	0,496	0,992	1,488	1,984	2,480	2,976	3,472	3,968
5	0,452	0,904	1,356	1,808	2,260	2,712	3,164	3,616
5,6	0,404	0,808	1,212	1,616	2,020	2,424	2,828	3,232
6,3	0,358	0,716	1,074	1,432	1,790	2,148	2,506	2,864
7,2	0,312	0,624	0,936	1,248	1,560	1,872	2,184	2,496
8,4	0,270	0,540	0,810	1,080	1,350	1,620	1,890	2,160
10	0,224	0,448	0,672	0,896	1,120	1,344	1,568	1,792
12,5	0,180	0,360	0,540	0,720	0,900	1,080	1,260	1,440
16,6	0,136	0,272	0,408	0,544	0,680	0,816	0,952	1,088
25	0,090	0,180	0,270	0,360	0,450	0,540	0,630	0,720
33	0,068	0,136	0,204	0,272	0,340	0,408	0,476	0,544
50	0,045	0,090	0,135	0,180	0,225	0,270	0,315	0,360
56	0,040	0,079	0,119	0,158	0,198	0,238	0,277	0,317
63	0,036	0,072	0,109	0,145	0,181	0,217	0,253	0,290
72	0,032	0,064	0,096	0,128	0,160	0,192	0,224	0,256
84	0,027	0,055	0,082	0,110	0,137	0,164	0,192	0,219
100	0,023	0,045	0,068	0,090	0,113	0,136	0,158	0,181
125	0,018	0,036	0,055	0,073	0,091	0,109	0,127	0,146
166	0,014	0,028	0,041	0,055	0,069	0,083	0,097	0,110
250	0,009	0,018	0,026	0,035	0,044	0,053	0,062	0,070
500	0,004	0,009	0,013	0,018	0,022	0,026	0,031	0,035
1000	0,002	0,004	0,006	0,008	0,010	0,012	0,014	0,016



**12.3.2 6 bar (g)**

Residual oil content in ppm (parts per million) at an operating pressure of 6 bar(g) :

Scale [h] Duration	0,2	0,4	0,6	0,8	1,0	1,2	1,4	1,6
4,2	0,640	1,280	1,920	2,560	3,200	3,840	4,480	5,120
4,5	0,580	1,160	1,740	2,320	2,900	3,480	4,060	4,640
5	0,524	1,048	1,572	2,096	2,620	3,144	3,668	4,192
5,6	0,454	0,908	1,362	1,816	2,270	2,724	3,178	3,632
6,3	0,416	0,832	1,248	1,664	2,080	2,496	2,912	3,328
7,2	0,364	0,728	1,092	1,456	1,820	2,184	2,548	2,912
8,4	0,312	0,624	0,936	1,248	1,560	1,872	2,184	2,496
10	0,266	0,532	0,798	1,064	1,330	1,596	1,862	2,128
12,5	0,210	0,420	0,630	0,840	1,050	1,260	1,470	1,680
16,6	0,160	0,320	0,480	0,640	0,800	0,960	1,120	1,280
25	0,105	0,210	0,315	0,420	0,525	0,630	0,735	0,840
33	0,078	0,156	0,234	0,312	0,390	0,468	0,546	0,624
50	0,053	0,106	0,158	0,211	0,264	0,317	0,370	0,422
56	0,047	0,093	0,140	0,186	0,233	0,280	0,326	0,373
63	0,042	0,083	0,125	0,166	0,208	0,250	0,291	0,333
72	0,037	0,074	0,110	0,147	0,184	0,221	0,258	0,294
84	0,032	0,064	0,096	0,128	0,160	0,192	0,224	0,256
100	0,027	0,054	0,080	0,107	0,134	0,161	0,188	0,214
125	0,020	0,041	0,061	0,082	0,102	0,122	0,143	0,163
166	0,016	0,032	0,048	0,064	0,080	0,096	0,112	0,128
250	0,011	0,021	0,032	0,042	0,053	0,064	0,074	0,085
500	0,005	0,010	0,016	0,021	0,026	0,031	0,036	0,042
1000	0,003	0,005	0,008	0,010	0,013	0,016	0,018	0,021

## Appendix and technical documents

### 12.3.3 5 bar (g)

Residual oil content in ppm (parts per million) at an operating pressure of 5 bar(g) :

Scale [h] Duration	0,2	0,4	0,6	0,8	1,0	1,2	1,4	1,6
4,2	0,700	1,400	2,100	2,800	3,500	4,200	4,900	5,600
4,5	0,700	1,400	2,100	2,800	3,500	4,200	4,900	5,600
5	0,636	1,272	1,908	2,544	3,180	3,816	4,452	5,088
5,6	0,568	1,136	1,704	2,272	2,840	3,408	3,976	4,544
6,3	0,500	1,000	1,500	2,000	2,500	3,000	3,500	4,000
7,2	0,438	0,876	1,314	1,752	2,190	2,628	3,066	3,504
8,4	0,380	0,760	1,140	1,520	1,900	2,280	2,660	3,040
10	0,316	0,632	0,948	1,264	1,580	1,896	2,212	2,528
12,5	0,254	0,508	0,762	1,016	1,270	1,524	1,778	2,032
16,6	0,190	0,380	0,570	0,760	0,950	1,140	1,330	1,520
25	0,126	0,252	0,378	0,504	0,630	0,756	0,882	1,008
33	0,096	0,192	0,288	0,384	0,480	0,576	0,672	0,768
50	0,062	0,124	0,186	0,248	0,310	0,372	0,434	0,496
56	0,057	0,114	0,172	0,229	0,286	0,343	0,400	0,458
63	0,050	0,101	0,151	0,202	0,252	0,302	0,353	0,403
72	0,044	0,088	0,132	0,176	0,220	0,264	0,308	0,352
84	0,038	0,076	0,114	0,152	0,190	0,228	0,266	0,304
100	0,032	0,064	0,096	0,128	0,160	0,192	0,224	0,256
125	0,026	0,051	0,077	0,102	0,128	0,154	0,179	0,205
166	0,018	0,037	0,055	0,074	0,092	0,110	0,129	0,147
250	0,013	0,027	0,040	0,054	0,067	0,080	0,094	0,107
500	0,006	0,012	0,018	0,024	0,030	0,036	0,042	0,048
1000	0,003	0,006	0,009	0,012	0,015	0,018	0,021	0,024

### 12.3.4 4 bar (g)

Residual oil content in ppm (parts per million) at an operating pressure of 4 bar(g) :

Scale [h] Duration	0,2	0,4	0,6	0,8	1,0	1,2	1,4	1,6
4,2	0,940	1,880	2,820	3,760	4,700	5,640	6,580	7,520
4,5	0,860	1,720	2,580	3,440	4,300	5,160	6,020	6,880
5	0,780	1,560	2,340	3,120	3,900	4,680	5,460	6,240
5,6	0,700	1,400	2,100	2,800	3,500	4,200	4,900	5,600
6,3	0,624	1,248	1,872	2,496	3,120	3,744	4,368	4,992
7,2	0,550	1,100	1,650	2,200	2,750	3,300	3,850	4,400
8,4	0,470	0,940	1,410	1,880	2,350	2,820	3,290	3,760
10	0,390	0,780	1,170	1,560	1,950	2,340	2,730	3,120
12,5	0,310	0,620	0,930	1,240	1,550	1,860	2,170	2,480
16,6	0,236	0,472	0,708	0,944	1,180	1,416	1,652	1,888
25	0,156	0,312	0,468	0,624	0,780	0,936	1,092	1,248
33	0,116	0,232	0,348	0,464	0,580	0,696	0,812	0,928
50	0,080	0,160	0,240	0,320	0,400	0,480	0,560	0,640
56	0,073	0,146	0,219	0,292	0,365	0,438	0,511	0,584
63	0,062	0,124	0,186	0,248	0,310	0,372	0,434	0,496
72	0,055	0,110	0,165	0,220	0,275	0,330	0,385	0,440
84	0,047	0,095	0,142	0,190	0,237	0,284	0,332	0,379
100	0,039	0,078	0,117	0,156	0,195	0,234	0,273	0,312
125	0,032	0,063	0,095	0,126	0,158	0,190	0,221	0,253
166	0,024	0,048	0,072	0,096	0,120	0,144	0,168	0,192
250	0,016	0,032	0,048	0,064	0,080	0,096	0,112	0,128
500	0,007	0,014	0,022	0,029	0,036	0,043	0,050	0,058
1000	0,004	0,008	0,012	0,016	0,020	0,024	0,028	0,032

### 12.4 General arrangement drawing

Separate document